

Representation Theory of Chern-Simons Observables

**Anton Yu. Alekseev
Volker Schomerus**

Vienna, Preprint ESI 214 (1995)

February 21, 1996

Supported by Federal Ministry of Science and Research, Austria
Available via <http://www.esi.ac.at>

Representation Theory of Chern-Simons Observables

ANTON YU. ALEKSEEV *

Institut für Theoretische Physik,
ETH – Hönggerberg, CH-8093 Zürich, Switzerland
and

Department of Mathematics, Harvard University †
Cambridge, MA 02138, U.S.A.

VOLKER SCHOMERUS ‡

Harvard University, Department of Physics
Cambridge, MA 02138, U.S.A.

March 29, 1995

Abstract

In [2], [3] we suggested a new quantum algebra, the moduli algebra, which is conjectured to be a quantum algebra of observables of the Hamiltonian Chern-Simons theory. This algebra provides the quantization of the algebra of functions on the moduli space of flat connections on a 2-dimensional surface. In this paper we classify unitary representations of this new algebra and identify the corresponding representation spaces with the spaces of conformal blocks of the WZW model. The mapping class group of the surface is proved to act on the moduli algebra by inner automorphisms. The generators of these automorphisms are unitary elements of the moduli algebra. They are constructed explicitly and proved to satisfy the relations of the (unique) central extension of the mapping class group.

*On leave of absence from Steklov Mathematical Institute, Fontanka 27, St.Petersburg, Russia; e-mail: alekseev@itp.phys.ethz.ch

†The visit of A.A. to Harvard University has been supported by Alfred P. Sloan Foundation Grant No 90-10-13

‡Supported in part by DOE Grant No DE-FG02-88ER25065; e-mail: mathphys@huhepl.harvard.edu

Contents

1	Introduction	2
I	Background Review	3
2	Chern-Simons Theory and the Moduli Space of Flat Connections	3
2.1	Combinatorial description	4
2.2	Poisson structure of the moduli space	5
3	Quantization of the Moduli Space	7
3.1	Quasi-triangular Hopf algebras	8
3.2	The graph algebra $\mathcal{L}_{g,m}$	10
3.3	Integration and *-properties of graph algebras	13
3.4	The moduli algebra	15
3.5	The finite-dimensional case	17
4	Summary of Results	19
4.1	Representation theory of the moduli algebra	19
4.2	The action of the mapping class group on the moduli algebra	20
4.3	Comparison to other approaches	21
II	Representation Theory of the Moduli Algebra	22
5	The Loop Algebra and its Representations	23
5.1	The loop algebra \mathcal{L}	23
5.2	Representation theory of the loop algebra \mathcal{L}	24
5.3	Gauss decomposition and loop-symmetry isomorphism	27
6	The Moduli Algebra on a Sphere with Marked Points	28
6.1	The graph algebra \mathcal{L}_m	28
6.2	Representation theory of the graph algebra \mathcal{L}_m	29
6.3	The moduli algebra $\mathcal{M}_m^{\{K_\nu\}}$	31
6.4	The first pinching theorem	34
7	The Handle Algebra and its Representations	37
7.1	The AB -algebra	37
7.2	Representation theory of the AB -algebra	37
7.3	Embedding the loop algebra into the AB -algebra	39

8	The Moduli Algebra for Higher Genera	43
8.1	Representation theory of the graph algebra $\mathcal{L}_{g,m}$	43
8.2	The moduli algebra $\mathcal{M}_g^{\{K_\nu\}}$	45
8.3	The second pinching theorem	46
9	Representations of Mapping Class Groups	47
9.1	Action of the mapping class group on moduli algebras	47
9.2	Projective representations of mapping class groups	49
9.3	Equivalence with Reshetikhin Turaev representation	51
10	Comments	56
10.1	Truncation	56
10.2	Open problems	58

1 Introduction

This paper is devoted to operator approach to quantization of the Chern-Simons theory, sometimes called Combinatorial Quantization. From a more mathematical perspective this is the same as quantization of the algebra of functions on the moduli space of flat connections on a Riemann surface. In [2], [3] we suggested the definition of the moduli algebra which solves this problem and investigated some elementary properties of this object.

In order to make the paper more accessible to the reader, we collect in Part 1 some motivations which lead to the idea of Combinatorial Quantization (following [21]) and some results and constructions from [2], [3]. This provides a background for the further consideration. We formulate the main results in Section 4.

In Sections 5-8 we deal with the representation theory of the moduli algebra. All unitary representations are classified for moduli algebras corresponding to surfaces of any genus with arbitrary number of marked points. The results are in agreement with other methods of quantization of the moduli space, like geometric quantization [9] and Conformal Field Theory [43].

Section 9 includes results on the action of the mapping class group of the surface on the quantized moduli space. As the mapping class group is acting on the moduli space of flat connections before quantization, it is natural to expect that this action survives in the quantum case. This is confirmed by the experience of Conformal Field Theory and we will indeed establish this result in the framework of Combinatorial Quantization. Unitary generators of the mapping class group action are described as elements of the moduli algebra by explicit formulae. They are proved to satisfy the relations for the (unique) central extension of the mapping class group.

In this work we extensively use certain results and ideas of the recent papers related to the program of Combinatorial Quantization [21], [11], [2], [3], [12], [7], [40], [5].

Part I

Background Review

2 Chern-Simons Theory and the Moduli Space of Flat Connections

The Chern-Simons theory is constructed by the following data. We pick up some semi-simple Lie algebra \mathfrak{g} , a coupling constant k and a 3-manifold M . The Chern-Simons action is a functional of a \mathfrak{g} -valued gauge field A on M and has the form

$$CS(A) = \frac{k}{4\pi} Tr \int_M (A \wedge dA + \frac{2}{3} A^3). \quad (2.1)$$

We do not describe truly exceptional properties of this action and of the corresponding theory and refer the reader to the original papers and numerous reviews. Let us only mention that for \mathfrak{g} being a compact Lie algebra, k is required to be integer in order to ensure the global gauge invariance.

When the manifold M has a structure of a direct product of a 2-dimensional surface and a segment of a real line, the Chern-Simons theory admits a Hamiltonian interpretation. As in any topological theory, the Hamiltonian is equal to zero. The action (2.1) induces a symplectic structure on the space of connections [8]:

$$\Omega = \frac{k}{4\pi} Tr \int_{\Sigma} \delta_1 A \wedge \delta_2 A. \quad (2.2)$$

This symplectic form is invariant with respect to gauge transformations

$$A^g = gAg^{-1} + dg g^{-1}. \quad (2.3)$$

An easy check shows that the moment map for the gauge group action is proportional to the curvature

$$F = dA + A^2. \quad (2.4)$$

The condition

$$F = 0 \quad (2.5)$$

emerges as a constraint from the Chern Simons action. From this analysis we see that the phase space of the Chern Simons model is a quotient of the space of flat connections (2.5) over the gauge group action (2.3). In this paper we often refer to this space as moduli space which should always be understood as a moduli space of flat connections on a Riemann surface.

2.1 Combinatorial description

Let us introduce a more efficient finite-dimensional description of the moduli space which will be of use throughout the paper. At the same moment we introduce moduli spaces on surfaces with marked points. Let G be a semi-simple connected simply-connected Lie group corresponding to the Lie algebra \mathfrak{g} and $\Sigma_{g,m}$ be a surface of genus g with m marked points. Assign a conjugacy class $\mathcal{C}_\nu \in G$ to the ν 's marked point. Denote $\pi = \pi_{g,m}$ the fundamental group of the surface $\Sigma_{g,m}$. The group π may be generated by $2g + m$ invertible generators $a_i, b_i, i = 1, \dots, g$ and $l_\nu, \nu = 1, \dots, m$ subject to the relation

$$[b_g, a_g^{-1}] \dots [b_1, a_1^{-1}] l_m \dots l_1 = id \quad . \quad (in \pi) \quad (2.6)$$

Here $[x, y]$ stays for the group commutator $xyx^{-1}y^{-1}$.

Definition 1 *The moduli space of flat connections $\mathbf{m}_{g,m}^{\{\mathcal{C}_\nu\}}$ on the Riemann surface of genus g with m marked points is defined as*

$$\mathbf{m}_{g,m}^{\{\mathcal{C}_\nu\}} = \{ \rho \in Hom(\pi, G), \rho(l_\nu) \in \mathcal{C}_\nu \} / G \quad . \quad (2.7)$$

Here the group G acts on the space of representations of π by conjugations

$$\rho^g(x) = g^{-1} \rho(x) g \quad . \quad (2.8)$$

In order to make contact with the definition which involves flat connections we represent generators of π as circles on $\Sigma_{g,m}$ intersecting at the base point on the surface. Then a flat connection A induces a representation of the fundamental group via

$$\begin{aligned} M_\nu &= \rho(l_\nu) = Hol(A, l_\nu) \quad ; \\ A_i &= \rho(a_i) = Hol(A, a_i) \quad ; \\ B_i &= \rho(b_i) = Hol(A, b_i) \quad . \end{aligned} \quad (2.9)$$

Here $Hol(A, x)$ is a holonomy of the connection A along the cycle x . Connection A being flat, ρ satisfies the defining relation

$$M = [B_g, A_g^{-1}] \dots [B_1, A_1^{-1}] M_m \dots M_1 = id \quad . \quad (in G) \quad (2.10)$$

The case of a surface with marked points requires some further comment. The marked points are deleted from the surface and the condition of flatness does not hold there. In general we permit the curvature to develop δ -function singularities at the marked points:

$$F = \sum_\nu T_\nu \delta^{(2)}(z - z_\nu) \quad . \quad (2.11)$$

Here T_ν 's are elements of the algebra \mathfrak{g} . However, if one permits arbitrary T_ν 's, the space of all connections fails to be symplectic. It regains this property if we

fix conjugacy classes of T_ν in \mathfrak{g} . This condition may be naturally derived from the Chern-Simons action functional in the same fashion as one obtains the flatness condition for a surface without marked points [17].

Assume that we have fixed some conjugacy classes for T_ν 's in the modified flatness condition (2.11). Then via equations (2.9) one can define a subset of representations of the fundamental group of a surface with marked points. It is easy to check that the condition (2.11) implies that $\rho(l_\nu)$ belong to certain conjugacy classes in the group G as it is stated in the definition of the moduli space. In fact, one can get the conjugacy class of $\rho(l_\nu)$ by applying the exponential map $exp : \mathfrak{g} \rightarrow G$ to the conjugacy class of T_ν . In this way we obtain a family of symplectic spaces labeled by two nonnegative integers (genus and the number of marked points) and by conjugacy classes attached to the marked points.

Notations (2.9) prove to be quite useful when constructing functions on the moduli space. Take any function f on the the direct product of $2g + m$ copies of the group G which is invariant with respect to simultaneous conjugations of the arguments

$$f(g^{-1}g_1g, \dots, g^{-1}g_{(2g+m)}g) = f(g_1, \dots, g_{(2g+m)}) \quad . \quad (2.12)$$

Define a function $f(\rho)$ on the space of representations via

$$f(\rho) = f(M_1, \dots, M_m, A_1, B_1, \dots, A_g, B_g). \quad (2.13)$$

It is easy to see that this function descends to the quotient space. In fact, any analytic function on the moduli space may be obtained in this way.

2.2 Poisson structure of the moduli space

As the quantization program which we are going to develop is close to deformation quantization, we describe the Poisson bracket on the moduli space defined by Atiyah-Bott symplectic structure. This Poisson bracket was described in [23]. However, we use another description of the same object which was especially designed for the needs of deformation quantization [21].

Let us introduce some useful notations. We define left and right invariant differential operators on a Lie group with values in the dual space to its Lie algebra:

$$\begin{aligned} \langle \nabla_L f(g), X \rangle &= \frac{d}{dt} f(e^{-tX}g)|_{t=0} \quad ; \\ \langle \nabla_R f(g), X \rangle &= \frac{d}{dt} f(ge^{tX})|_{t=0} \quad . \end{aligned} \quad (2.14)$$

As we work with semi-simple algebras, one can introduce a nondegenerate Killing form $K \in \mathfrak{g} \otimes \mathfrak{g}$. Let us consider one more element $r \in \mathfrak{g} \otimes \mathfrak{g}$. It is called classical r -matrix if it satisfies the classical Yang-Baxter equation in $U(\mathfrak{g})^{\otimes 3}$:

$$[r_{12}, r_{13}] + [r_{12}, r_{23}] + [r_{13}, r_{23}] = 0 \quad . \quad (2.15)$$

Here we denote $r_{12} = r \otimes 1$, r_{13} and r_{23} are constructed in a similar way. For any solution r of the classical Yang-Baxter equation one can construct another solution r' which is obtained by permutation of two copies of \mathfrak{g} . Let us prepare their symmetric and antisymmetric combinations

$$r_s = \frac{1}{2}(r + r') \quad , \quad r_a = \frac{1}{2}(r - r') \quad . \quad (2.16)$$

In general, neither r_a nor r_s satisfy the classical Yang-Baxter equation.

In order to describe the Poisson bracket on the moduli space we use its description via representations of the fundamental group from the previous subsection. As the space of representations is embedded into G^{2g+m} , it is convenient to order the $2(2g+m)$ covariant differential operators in the following way

$$\begin{aligned} \nabla_{2\nu-1} &= \nabla_R^{M_\nu} \quad , \quad \nabla_{2\nu} = \nabla_L^{M_\nu} \quad \text{for } \nu = 1, \dots, m ; \\ \nabla_{m+4i-3} &= \nabla_R^{A_i} \quad , \quad \nabla_{m+4i-1} = \nabla_L^{A_i} \quad \text{for } i = 1, \dots, g ; \\ \nabla_{m+4i-2} &= \nabla_R^{B_i} \quad , \quad \nabla_{m+4i-1} = \nabla_L^{B_i} \quad \text{for } i = 1, \dots, g . \end{aligned} \quad (2.17)$$

One can rewrite the condition for a function f on G^{2g+m} to be invariant in the sense of (2.12) as

$$\sum_{s=1}^{2(2g+m)} \nabla_s f = 0 \quad . \quad (2.18)$$

With these notations we present a description of the Poisson structure on the moduli space.

Theorem 2 (Fock-Rosly [21]) *Let $r \in \mathfrak{g} \otimes \mathfrak{g}$ be a solution of the classical Yang-Baxter equation. Assume that its symmetric part coincides with the Killing bilinear $r_s = K$. Introduce a Poisson bracket on G^{2g+m} by the following formula*

$$\{f, h\} = \frac{1}{2} \sum_i \langle r, \nabla_i f \wedge \nabla_i h \rangle + \sum_{i < j} \langle r, \nabla_i f \wedge \nabla_j h \rangle \quad . \quad (2.19)$$

This Poisson bracket restricts to the space of functions which are invariant with respect to simultaneous conjugations. Being mapped to the moduli space by means of equation (2.13), the bracket (2.19) coincides with the canonical Poisson bracket defined by the Atiyah-Bott symplectic structure.

The Poisson bracket (2.19) may be easily evaluated for simplest functions on G^{2g+m} . Examples of such functions are given by matrix elements of M_ν , A_i and B_i evaluated in some irreducible representations. We denote a matrix which represents some $X \in G$ in the representation τ^I by X^I . Applying a pair of representations τ^I and τ^J to the classical r -matrix we produce $r^{IJ} = (\tau^I \otimes \tau^J)(r)$.

It is convenient to introduce tensor notations $X^1 = X \otimes 1, X^2 = 1 \otimes X$. Let us give some examples of Poisson brackets for particular matrix elements:

$$\begin{aligned} \{M_\nu^I, M_\mu^J\} &= r^{IJ} M_\nu^I M_\mu^J - M_\nu^I r^{IJ} M_\mu^J \\ &\quad - M_\mu^J r^{IJ} M_\nu^I + M_\nu^I M_\mu^J r^{IJ} \quad \text{for } \nu < \mu ; \\ \{M_\nu^I, M_\nu^J\} &= r^{IJ} M_\nu^I M_\nu^J - M_\nu^I r^{IJ} M_\nu^J \\ &\quad - M_\nu^J (r')^{IJ} M_\nu^I + M_\nu^I M_\nu^J (r')^{IJ} ; \end{aligned} \quad (2.20)$$

$$\{A_i^I, B_i^J\} = r^{IJ} A_i^I B_i^J - A_i^I r^{IJ} B_i^J - B_i^J (r')^{IJ} A_i^I + A_i^I B_i^J r'^{IJ} .$$

As one can see, a Poisson bracket of two matrix elements is quadratic in matrix elements of the same representations. Classical r -matrices r^{IJ} and $(r')^{IJ}$ play the role of structure constants in this Poisson bracket algebra. This point is the most important observation of [21] as it makes it possible to proceed with quantization of the algebra of functions on the moduli space.

Matrix elements of M_ν, A_i, B_i which we considered so far do not define functions on the moduli space as they are not invariant with respect to conjugations. Let us remark that the Poisson bracket (2.19) is not conjugation invariant. Nevertheless it may be consistently restricted to the set of conjugation invariant functions which means that a Poisson bracket of two such functions is again conjugation invariant. Conjugation invariant functions are produced as linear combinations of elements

$$tr^J \left(C_1 [I_1, \dots, I_{2g+m} | J] M_1^{I_1} \dots M_m^{I_m} A_1^{I_{m+1}} \dots B_g^{I_{2g+m}} C_2 [I_1, \dots, I_{2g+m} | J]^* \right)$$

for arbitrary sets of labels $\{I_\nu\}, J$ and two intertwiners $C_1, C_2 : V^{I_1} \otimes \dots \otimes V^{I_{2g+m}} \mapsto V^J$.

As we have seen in the previous subsection, any invariant function on G^{2g+m} defines a function on the moduli space. In fact, we restrict an invariant function to the subset defined by the conditions (cp. formula 2.10 for notations)

$$M_\nu \in \mathcal{C}_\nu \quad , \quad M = 1 \quad . \quad (2.21)$$

By the theorem of Fock and Rosly this restriction is consistent with the structure of the bracket. This means that constraints (2.21) are preserved by Hamiltonian flows produced by invariant functions. As it is stated in Theorem 2, the resulting bracket on the moduli space coincides with the canonical one.

3 Quantization of the Moduli Space

As we mentioned above, the structure constants of Poisson algebra (2.19) are defined by a couple of classical r -matrices r and r' . The key point in the quantization procedure is the fact that we know a family of solutions of the quantum

Yang-Baxter equation

$$R_{12}R_{13}R_{23} = R_{23}R_{13}R_{12} \quad (3.22)$$

labeled by a parameter h so that

$$R^{IJ}|_{h \rightarrow 0} = I + hr + \mathcal{O}(h^2) \quad . \quad (3.23)$$

We assume that R^{IJ} exist for any I and J and that they are represented by matrices in the same spaces as r^{IJ} . Our intention is to replace the Poisson algebra with structure constants r, r' by an associative algebra with structure constants R, R' . A natural framework for this construction is provided by the theory of quasi-triangular Hopf algebras.

3.1 Quasi-triangular Hopf algebras

The objects we wish to investigate later are associated with a quantum symmetry algebra \mathcal{G} . More precisely, \mathcal{G} is a ribbon Hopf- $*$ -algebra, i.e. a $*$ -algebra \mathcal{G} with co-unit $\epsilon : \mathcal{G} \mapsto \mathbf{C}$, co-product $\Delta : \mathcal{G} \mapsto \mathcal{G} \otimes \mathcal{G}$, antipode $\mathcal{S} : \mathcal{G} \mapsto \mathcal{G}$, R -matrix $R \in \mathcal{G} \otimes \mathcal{G}$ and the ribbon element $v \in \mathcal{G}$. We do not want to spell out all the standard axioms these objects have to satisfy in order to give a ribbon Hopf algebra (for a complete definition see e.g. [37]). Let us stress, however, that we deal with structures for which the co-product Δ is consistent with the action

$$(\xi \otimes \eta)^* = \eta^* \otimes \xi^* \quad \text{for all } \eta, \xi \in \mathcal{G}$$

of the $*$ -operation $*$ on elements in the tensor product $\mathcal{G} \otimes \mathcal{G}$. This case is of particular interest, since it appears for the quantized universal enveloping algebras $U_q(\mathfrak{g})$ when the complex parameter q has values on the unit circle [33].

Given the standard expansion of $R \in \mathcal{G} \otimes \mathcal{G}$, $R = \sum r_\sigma^1 \otimes r_\sigma^2$, one constructs the elements

$$u = \sum \mathcal{S}(r_\sigma^2) r_\sigma^1 \quad . \quad (3.1)$$

Among the properties of u (cp. e.g. [37]) one finds that the product $u\mathcal{S}(u)$ is in the center of \mathcal{G} . The ribbon element v is a central square root of $u\mathcal{S}(u)$ which obeys the following relations

$$v^2 = u\mathcal{S}(u) \quad , \quad \mathcal{S}(v) = v \quad , \quad \epsilon(v) = 1 \quad , \quad (3.2)$$

$$v^* = v^{-1} \quad , \quad \Delta(v) = (R'R)^{-1}(v \otimes v) \quad . \quad (3.3)$$

The elements u and v can be combined to furnish a grouplike unitary element $g = u^{-1}v \in \mathcal{G}$. Examples of ribbon-Hopf- $*$ -algebras are given by the enveloping algebras of all simple Lie algebras [37].

In the following we make several additional assumptions about the ribbon Hopf algebra \mathcal{G} . To begin with, we will assume that \mathcal{G} is *semisimple*. More restrictions will be imposed in subsection 3.4 .

For every equivalence class $[J]$ of irreducible $*$ -representations of \mathcal{G} we pick a particular representative τ^J with carrier space V^J . The tensor product $\tau^I \boxtimes \tau^J$ of two representations τ^I, τ^J of the semisimple algebra \mathcal{G} can be decomposed into irreducibles τ^K . This decomposition determines the Clebsch-Gordon maps $C^a[IJ|K] : V^I \otimes V^J \mapsto V^K$,

$$C^a[IJ|K](\tau^I \boxtimes \tau^J)(\xi) = \tau^K(\xi) C^a[IJ|K] \quad . \quad (3.4)$$

The same representations τ^K in general appears with some multiplicity N_K^{IJ} . The superscript $a = 1, \dots, N_K^{IJ}$ keeps track of these subrepresentations. It is common to call the numbers N_K^{IJ} *fusion rules*. Normalization of these Clebsch Gordon maps is connected with an extra assumption. Notice that the ribbon element v is central so that the evaluation with irreducible representations τ^I gives complex numbers $v_I = \tau^I(v)$. We suppose that there exists a set of square roots $\kappa_I, \kappa_I^2 = v_I$, such that

$$C^a[IJ|K](R')^{IJ} C^b[IJ|L]^* = \delta_{a,b} \delta_{K,L} \frac{\kappa_I \kappa_J}{\kappa_K} \quad . \quad (3.5)$$

Here $R' = \sum r_\sigma^2 \otimes r_\sigma^1$ and $(R')^{IJ} = (\tau^I \otimes \tau^J)(R')$. The adjoint of the Clebsch Gordon map is meant with respect to the standard scalar product on $V^I \otimes V^J$ induced by the scalar products on V^I, V^J . Let us analyze this relation in more detail. As a consequence of intertwining properties of the Clebsch Gordon maps and the R -element, $\tau^K(\xi)$ commutes with the left hand side of the equation. So by Schurs' lemma, it is equal to the identity e^K times some complex factor $\omega_{ab}(IJ|K)$. After appropriate normalization, $\omega_{ab}(IJ|K) = \delta_{a,b} \omega(IJ|K)$ with a complex phase $\omega(IJ|K)$. Next we exploit the $*$ -operation and relation (3.3) to find $\omega_{ab}(IJ|K)^2 = v_I v_J / v_K$. This means that (3.5) can be ensured up to a possible sign \pm . Here we assume that this sign is always $+$. This assumption was crucial for the positivity in [2]. It is met by the quantized universal enveloping algebras of all simple Lie algebras because they are obtained as deformations of Hopf-algebras which clearly satisfy (3.5). As a consequence of the normalization equation (3.5) and the equation $\Delta(\epsilon) = \epsilon \otimes \epsilon$ we obtain the following completeness

$$\sum_{K,a} \frac{\kappa_K}{\kappa_I \kappa_J} (R')^{IJ} C^a[IJ|K]^* C^a[IJ|K] = e^I \otimes e^J \quad . \quad (3.6)$$

We wish to combine the phases κ_I into one element κ in the center of \mathcal{G} , i.e. by definition, κ will denote a central element

$$\kappa \in \mathcal{G} \quad \text{with} \quad \tau^J(\kappa) = \kappa_J \quad . \quad (3.7)$$

Such an element does exist and is unique. It has the property $\kappa^* = \kappa^{-1}$.

The antipode \mathcal{S} of \mathcal{G} furnishes a conjugation in the set of equivalence classes of irreducible representations. We use $[\bar{J}]$ to denote the class conjugate to $[J]$. Some important properties of the fusion rules N_K^{IJ} can be formulated with the help of this conjugation. Among them are the relations

$$N_0^{K\bar{K}} = 1 \quad , \quad N_K^{IJ} = N_K^{JI} = N_I^{JK} \quad . \quad (3.8)$$

The numbers v_I are symmetric under conjugation, i.e. $v_K = v_{\bar{K}}$.

The q -trace of an element $X \in \text{End}(V^K)$ is defined by

$$\text{tr}_q^K(X) = \text{tr}^K(X\tau^K(g)) \quad (3.9)$$

where $g = u^{-1}v$ is the grouplike element introduced above. Let us also mention that the q -trace of the identity map $e^K \in \text{End}(V^K)$ computes the ‘‘quantum dimension’’ d_K of the representation τ^K [37], i.e.

$$d_K \equiv \text{tr}_q^K(e^K) \quad . \quad (3.10)$$

The numbers d_K satisfy the equalities $d_I d_J = \sum N_K^{IJ} d_K$ and $d_K = d_{\bar{K}}$. In general, the quantum dimensions d_I differ from the dimensions δ_I of the representation spaces V^I .

3.2 The graph algebra $\mathcal{L}_{g,m}$

Equipped with the technique and notations of the preceding subsection we introduce a quantized version of the Poisson algebra (2.19) on G^{2g+m} . This is the first step towards quantization of the moduli space.

Definition 3 (Graph algebra $\mathcal{L}_{g,m}$) *The graph-algebra $\mathcal{L}_{g,m}$ is an associative algebra generated by matrix elements of $M_\nu^I, A_i^I, B_i^I \in \text{End}(V^I) \otimes \mathcal{L}_{g,m}, \nu = 1, \dots, m, i = 1, \dots, g$. The superscript I runs through the set of irreducible representations of a quantum symmetry algebra \mathcal{G} with R -element R . Elements in $\mathcal{L}_{g,m}$ are subject to the following relations*

$$\overset{1}{M}_\nu^I R^{IJ} \overset{2}{M}_\nu^J = \sum C^a[IJ|K]^* M_\nu^K C^a[IJ|K] \quad , \quad (3.11)$$

$$\overset{1}{A}_i^I R^{IJ} \overset{2}{A}_i^J = \sum C^a[IJ|K]^* A_i^K C^a[IJ|K] \quad , \quad (3.12)$$

$$\overset{1}{B}_i^I R^{IJ} \overset{2}{B}_i^J = \sum C^a[IJ|K]^* B_i^K C^a[IJ|K] \quad , \quad (3.13)$$

$$(R^{-1})^{IJ} \overset{1}{A}_i^I R^{IJ} \overset{2}{B}_i^J = \overset{2}{B}_i^J (R^{-1})^{IJ} \overset{1}{A}_i^I R^{IJ} \quad , \quad (3.14)$$

$$(R^{-1})^{IJ} \overset{1}{M}_\nu^I R^{IJ} \overset{2}{M}_\mu^J = \overset{2}{M}_\mu^J (R^{-1})^{IJ} \overset{1}{M}_\nu^I R^{IJ} \quad \text{for } \nu < \mu \quad . \quad (3.15)$$

$$(R^{-1})^{IJ} \overset{1}{M}_\nu^I R^{IJ} \overset{2}{A}_j^J = \overset{2}{A}_j^J (R^{-1})^{IJ} \overset{1}{M}_\nu^I R^{IJ} \quad \text{for all } \nu, j \quad , \quad (3.16)$$

$$(R^{-1})^{IJ} \overset{1}{M}_\nu^I R^{IJ} \overset{2}{B}_j^J = \overset{2}{B}_j^J (R^{-1})^{IJ} \overset{1}{M}_\nu^I R^{IJ} \quad \text{for all } \nu, j \quad , \quad (3.17)$$

$$(R^{-1})^{IJ} \overset{1}{A}_i^I R^{IJ} \overset{2}{A}_j^J = \overset{2}{A}_j^J (R^{-1})^{IJ} \overset{1}{A}_i^I R^{IJ} \quad \text{for } i < j \quad , \quad (3.18)$$

$$(R^{-1})^{IJ} \overset{1}{B}_i^I R^{IJ} \overset{2}{B}_j^J = \overset{2}{B}_j^J (R^{-1})^{IJ} \overset{1}{B}_i^I R^{IJ} \quad \text{for } i < j \quad , \quad (3.19)$$

$$(R^{-1})^{IJ} \overset{1}{A}_i^I R^{IJ} \overset{2}{B}_j^J = \overset{2}{B}_j^J (R^{-1})^{IJ} \overset{1}{A}_i^I R^{IJ} \quad \text{for } i < j \quad , \quad (3.20)$$

$$(R^{-1})^{IJ} \overset{1}{B}_i^I R^{IJ} \overset{2}{A}_j^J = \overset{2}{A}_j^J (R^{-1})^{IJ} \overset{1}{B}_i^I R^{IJ} \quad \text{for } i < j \quad . \quad (3.21)$$

Now we motivate and discuss some pieces of this long definition.

First of all, the most part of defining relations are quantized counterparts of Poisson brackets (2.19). Let us pick as example equation

$$(R^{-1})^{IJ} \overset{1}{A}_i^I R^{IJ} \overset{2}{B}_i^J = \overset{2}{B}_i^J (R')^{IJ} \overset{1}{A}_i^I R^{IJ} \quad . \quad (3.22)$$

In order to recover the Poisson algebra one has to use the standard Ansatz of quantum mechanics (axiomatized by the deformation quantization theory).

Definition 4 *Let X and Y be elements of an associative algebra defined over formal power series in \hbar . Assume that this algebra becomes abelian for $\hbar = 0$ and*

$$XY - YX = \hbar Z_1 + \hbar^2 Z_2 + \dots \quad . \quad (3.23)$$

Then the Poisson bracket of X and Y is defined as

$$\{X, Y\} = Z_1 \quad . \quad (3.24)$$

Applying this definition to equation (3.22) we expand quantum R -matrices into the power series in \hbar . As a coefficient at \hbar^0 we discover the commutator of $\overset{1}{A}_i^I$ and $\overset{2}{B}_i^J$ which fits to the l.h.s. of (3.23). To evaluate the first order in \hbar we use formula (3.23) and recover the Poisson bracket as presented in the r.h.s. of the last equation in (2.20).

What seems to be missing in this picture is counterparts of mutual Poisson brackets of matrix elements of the same holonomy. Let us temporarily reintroduce these missing relations:

$$\begin{aligned} (R^{-1})^{IJ} \overset{1}{A}_i^I R^{IJ} \overset{2}{A}_i^J &= \overset{2}{A}_i^J (R')^{IJ} \overset{1}{A}_i^I (R'^{-1})^{IJ} \quad , \\ (R^{-1})^{IJ} \overset{1}{B}_i^I R^{IJ} \overset{2}{B}_i^J &= \overset{2}{B}_i^J (R')^{IJ} \overset{1}{B}_i^I (R'^{-1})^{IJ} \quad , \\ (R^{-1})^{IJ} \overset{1}{M}_\nu^I R^{IJ} \overset{2}{M}_\nu^J &= \overset{2}{M}_\nu^J (R')^{IJ} \overset{1}{M}_\nu^I (R'^{-1})^{IJ} \quad . \end{aligned} \quad (3.25)$$

Together with other quadratic relations of the last definition, equations (3.25) provide a quantization of the Poisson bracket (2.19). Let us mention that in fact formula (2.19) encodes the same number of equations as (3.14-3.21) together with (3.25). Quantum exchange relations look somewhat more complicated only for notational reasons.

The key observation which one can make looking at the quadratic relations (3.14-3.21), (3.25) is the presence of the Hopf algebra symmetry in the graph algebra. More explicitly, let ξ be an element of \mathcal{G} and

$$\Delta(\xi) = \sum \xi_\sigma^1 \otimes \xi_\sigma^2 \quad . \quad (3.26)$$

The action of ξ on the generators of $\mathcal{L}_{g,m}$ is defined as follows:

$$\begin{aligned}\xi(M_\nu^I) &= \sum_\sigma \tau^I(\mathcal{S}(\xi_\sigma^1)) M_\nu^I \tau^I(\xi_\sigma^2) \ , \\ \xi(A_i^I) &= \sum_\sigma \tau^I(\mathcal{S}(\xi_\sigma^1)) A_i^I \tau^I(\xi_\sigma^2) \ , \\ \xi(B_i^I) &= \sum_\sigma \tau^I(\mathcal{S}(\xi_\sigma^1)) B_i^I \tau^I(\xi_\sigma^2) \ .\end{aligned}\tag{3.27}$$

One can continue this action to the whole of $\mathcal{L}_{g,m}$ using the property of generalized derivations [39]

$$\xi(XY) = \sum_\sigma \xi_\sigma^1(X) \xi_\sigma^2(Y) \ .\tag{3.28}$$

Here X and Y are arbitrary elements of $\mathcal{L}_{g,m}$. Formulas (3.27) and (3.28) provide a proper generalization for the quantized case of simultaneous conjugations (2.12). Quadratic exchange relations which define the algebra $\mathcal{L}_{g,m}$ are invariant with respect to the action of the quantum symmetry in the following sense. For each of them

$$\xi(l.h.s) = \xi(r.h.s)\tag{3.29}$$

for any $\xi \in \mathcal{G}$.

There is no surprise that we discover the quantum invariance in the quadratic exchange relations. Indeed, they are defined by the same set of R -matrices as the quasi-triangular Hopf symmetry algebra.

In fact, we can make the quantum description closer to the classical one if we trade the action of \mathcal{G} for the coaction of the dual Hopf algebra \mathcal{G}^* . The latter is generated by the matrix elements of $g^I \in \text{End}(V^I) \otimes \mathcal{G}^*$. Among the others they satisfy quadratic exchange relations

$$R^{IJ} g^I g^J = g^J g^I R^{IJ}.\tag{3.30}$$

These are famous defining relations for the algebra of functions on a quantum group.

It is easy to check that the mapping $g : \mathcal{L}_{g,m} \rightarrow \mathcal{G}^* \otimes \mathcal{L}_{g,m}$ defined as

$$\begin{aligned}M_\nu^I &\rightarrow (g^I)^{-1} M_\nu^I g^I \ , \\ A_i^I &\rightarrow (g^I)^{-1} A_i^I g^I \ , \\ B_i^I &\rightarrow (g^I)^{-1} B_i^I g^I\end{aligned}\tag{3.31}$$

preserves exchange relations. The formalism (3.31) is more transparent. In particular, it has been extensively used in [12] for description of lattice gauge models with quantum gauge group. However, in view of the generalizations for the quasi-Hopf algebras, we stick to the more formal definition of the quantum invariance

which involves the action of \mathcal{G} rather than the coaction of \mathcal{G}^* . Let us stress that these two approaches are completely equivalent.

Now we can explain the origin of the first three relations in the definition of the graph algebra. Before quantization holonomies M_ν, A_i and B_i take values in the group G . This implies that matrix elements of the same holonomy in different representations are not algebraically independent. More explicitly, a product of two matrix elements of some holonomy matrix in two different representations may be decomposed into a sum of certain matrix elements by means of Clebsch-Gordon maps:

$$M_\nu^I M_\nu^J = \sum C_0^a[IJ|K]^* M_\nu^K C_0^a[IJ|K] . \quad (3.32)$$

Here the Clebsch-Gordon maps with the subscript 0 refer to the undeformed Lie group G .

Relations of the type (3.32) do not hold in the quantized algebra. They would contradict e.g. the quadratic exchange relations (3.25). The first three relations in the definition of the graph algebra provide a proper substitute for (3.32). They are chosen to be consistent with the symmetry Hopf algebra action (3.27), (3.28) on the graph algebra. Equations (3.25) follow from the multiplication laws (3.11-3.13). That is why we do not include (3.25) into the basic definition.

3.3 Integration and *-properties of graph algebras

This subsection is devoted to the *-operation and the integration measure on the graph algebras. These two objects are useful technical tools in the analysis of the representation theory. Also, the *-operation is important for the physical interpretation as an algebra of observables of a quantum system is always a *-algebra.

Let us recall that we assume consistency of the co-product for the Hopf symmetry algebra with the special kind of *-operation which reverses the order in the tensor product (see subsection 3.1). As a consequence of this choice the algebra $\mathcal{L}_{g,m}$ is *not* equipped with a natural *-operation. However, we can save the situation using the following trick.

The algebra \mathcal{G} acting on $\mathcal{L}_{g,m}$, we can define a semi-direct product $\mathcal{S}_{g,m}$ of these two objects. It is generated by the elements $\xi \in \mathcal{G}$ and by the elements of $\mathcal{L}_{g,m}$. In order to describe the commutation relations of the symmetry generators and the matrix elements of quantized holonomies it is convenient to introduce the generating matrices $\mu^I(\xi) \in \text{End}(V^I) \otimes \mathcal{G}$ for the symmetry algebra:

$$\mu^I(\xi) = (\tau^I \otimes id)\Delta(\xi) . \quad (3.33)$$

The cross relation between ξ and quantum holonomies in $\mathcal{S}_{g,m}$ look like

$$\mu^J(\xi)M_\nu^J = M_\nu^J\mu^J(\xi) , \quad (3.34)$$

$$\mu^J(\xi)A_i^J = A_i^J\mu^J(\xi) , \quad \mu^J(\xi)B_i^J = B_i^J\mu^J(\xi) . \quad (3.35)$$

The semi-direct product $\mathcal{S}_{g,m}$ is already a $*$ -algebra. The $*$ -operation on \mathcal{G} coincides with the genuine $*$ -operation of the symmetry algebra. It is continued to the quantum holonomies as [2]:

$$\begin{aligned} (M_\nu^I)^* &= \sigma_\kappa(R^I(M_\nu^I)^{-1}(R^{-1})^I) \ , \\ (A_i^I)^* &= \sigma_\kappa(R^I(A_i^I)^{-1}(R^{-1})^I) \ , \\ (B_i^I)^* &= \sigma_\kappa(R^I(B_i^I)^{-1}(R^{-1})^I) \ . \end{aligned} \quad (3.36)$$

Here we introduced $(M_\nu^I)^{-1}, (A_i^I)^{-1}, (B_i^I)^{-1} \in \text{End}(V^I) \otimes \mathcal{S}_{g,m}$ being the unique solutions of $M_\nu^I(M_\nu^I)^{-1} = e^I = (M_\nu^I)^{-1}M_\nu^I$, $A_i^I(A_i^I)^{-1} = e^I = (A_i^I)^{-1}A_i^I$ and $B_i^I(B_i^I)^{-1} = e^I = (B_i^I)^{-1}B_i^I$. The symbol σ_κ stays for the automorphism of $\mathcal{S}_{g,m}$ obtained by conjugation with the unitary element $\kappa \in \mathcal{G}$,

$$\sigma_\kappa(F) = \kappa^{-1}F\kappa$$

for any F .

Another important object which may be introduced for $\mathcal{S}_{g,m}$ is an invariant integration measure. We define a linear functional $\omega : \mathcal{S}_{g,m} \rightarrow \mathbf{C}$ as

$$\omega(M_1^{I_1} \dots B_g^{I_{m+2g}} \xi) = \epsilon(\xi) \prod_{s=1}^{m+2g} \delta_{I_s, 0} \ . \quad (3.37)$$

Formula (3.37) is defined on the set of monomials which span the algebra $\mathcal{S}_{g,m}$. So, ω is continued to the whole algebra as a linear functional. The integral (3.37) may be restricted to the algebra $\mathcal{L}_{g,m}$. There it furnishes the quantum analog of the multidimensional Haar measure on G^{m+2g} . In particular, one can formulate the invariance of ω as

$$\omega(\xi(X)) = \epsilon(\xi) \omega(X) \quad (3.38)$$

for any $\xi \in \mathcal{G}$ and $X \in \mathcal{L}_{g,m}$.

Usually an interplay between the $*$ -operation and the integration is the positivity property of the Hermitian scalar product defined by the integration functional

$$(X, Y) = \omega(X^*Y) \ .$$

However, this property never holds on $\mathcal{S}_{g,m}$ as ω always has a big kernel in \mathcal{G} . On the other hand, one can not formulate positivity on $\mathcal{L}_{g,m}$ as this is not a $*$ -algebra. So, instead of the usual positivity we formulate the following substitute.

Theorem 5 (Positivity [2]) *Assume that the quantum dimensions of all irreducible representations of the Hopf symmetry algebra \mathcal{G} are strictly positive*

$$d_I > 0 \text{ for every } I \ . \quad (3.39)$$

Then the restriction of the integral ω to $\mathcal{L}_{g,m}$ is positive in the following sense

$$\begin{aligned} \omega(X^*X) &\geq 0 \text{ for all } X \in \mathcal{L}_{g,m} \\ \text{and} \quad \omega(X^*X) = 0 &\Rightarrow X = 0 \ . \end{aligned} \quad (3.40)$$

One can find a proof of this theorem in [2].

Let us remark that the element X^* does not belong to $\mathcal{L}_{g,m}$. So, we need the bigger algebra $\mathcal{S}_{g,m}$ in order to make sense of (3.40). In fact, this kind of positivity on the level of graph algebras will be sufficient to provide positivity of the integration measure on the quantized moduli algebras.

3.4 The moduli algebra

The construction of the moduli space starting from G^{2g+m} involves two additional steps. First, one has to restrict the consideration to the subspace of invariant functions. Next, one imposes the conditions (2.21). We should find quantum counterparts of both operations.

It is straightforward to generalize the first step.

Definition 6 (Algebras $\mathcal{A}_{g,m}$) *$\mathcal{A}_{g,m}$ is defined as a subalgebra of elements $A \in \mathcal{L}_{g,m}$ which are invariant with respect to the natural action of \mathcal{G} , i.e. $\xi(A) = A\xi(\xi)$ for all $A \in \mathcal{A}_{g,m}$ and $\xi \in \mathcal{G}$.*

Since elements $\xi \in \mathcal{G}$ act trivially on $\mathcal{A}_{g,m}$, the semi-direct product of \mathcal{G} and $\mathcal{A}_{g,m}$ coincides with the usual Cartesian product $\mathcal{G} \times \mathcal{A}_{g,m}$ and hence the $*$ -operation on $\mathcal{S}_{g,m}$ furnishes a $*$ -operation on $\mathcal{A}_{g,m}$. Then the modified positivity which we defined on $\mathcal{L}_{g,m}$ ensures the usual positivity property of ω on $\mathcal{A}_{g,m}$. Let us also remark that elements of $\mathcal{A}_{g,m}$ are linear combinations of expressions of the form:

$$tr_q^J \left(C_1^q [I_1, \dots, I_{2g+m} | J] M_1^{I_1} \dots M_m^{I_m} A_1^{I_{m+1}} \dots B_g^{I_{2g+m}} C_2^q [I_1, \dots, I_{2g+m} | J]^* \right) .$$

Here tr_q is the q -trace, C_1^q, C_2^q are intertwining operators for the Hopf algebra action. For generic values of q one can establish an isomorphism of the linear spaces $\mathcal{A}_{g,m}$ and $\mathcal{A}_{g,m}^0$. The latter is the space of conjugation invariant analytic functions on G^{2g+m} . Obviously, this isomorphism can not be lifted to the level of algebraic structures as the space of functions is abelian whereas $\mathcal{A}_{g,m}$ is not.

To perform the second step of the reduction to the moduli space we single out a particular graph algebra corresponding to one marked point on a Riemann surface.

Definition 7 (Loop algebra \mathcal{L}) *The loop algebra \mathcal{L} is an associative algebra isomorphic to the graph algebra $\mathcal{L}_{0,1}$. It is generated by matrix elements of the monodromies $M^I \in \text{End}(V^I) \otimes \mathcal{L}$.*

Closely related to \mathcal{L} is the abelian fusion (or Verlinde) algebra.

Definition 8 (Fusion (or Verlinde) algebra) *Let \mathcal{G} be semi-simple (quasi-) Hopf $*$ -algebra. Its fusion (or Verlinde) algebra \mathcal{V} is an abelian $*$ -algebra spanned by the*

set of generators c^I . Here I runs through the set of all irreducible representations of \mathcal{G} . The multiplication law and the $*$ -operation in \mathcal{V} are defined as follows:

$$c^I c^J = \sum N_K^{IJ} c^K \quad \text{and} \quad (c^I)^* = c^I \quad . \quad (3.41)$$

One can employ the q -traces tr_q^I to construct central elements $c^I \in \mathcal{L}$ from the monodromies M^I

$$c^I = \kappa_I tr_q^I(M^I) \quad . \quad (3.42)$$

In [3] we have demonstrated that the elements (3.42) generate the Verlinde algebra.

It is important that under certain conditions (for details see Section 5) the representations of the loop algebra \mathcal{L} and of the corresponding Verlinde algebra \mathcal{V} may be labeled by the same set of labels as the representations of the symmetry algebra \mathcal{G} . Here we describe the representations of the Verlinde algebra by explicit formulas.

Let us introduce a (possibly infinite) matrix

$$s^{IJ} = (tr_q^I \otimes tr_q^J)(R'R) \quad (3.43)$$

with rows and columns labeled by the representations of \mathcal{G} . Equations

$$\vartheta^J(c^I) = \frac{s^{IJ}}{d^J} \quad (3.44)$$

define the set of representations of the Verlinde algebra. We shall see that in a quite general situation this set of representations is complete.

It is convenient to introduce a special notation for the relations

$$\Phi^J = \{c^I = \vartheta^J(c^I)\} \quad (3.45)$$

which restricts the generators c^I to a certain representation. Imposing these central relations we may get ideals in both \mathcal{V} and \mathcal{L} .

Returning to arbitrary values of g and m we introduce $m + 1$ embeddings of \mathcal{L} into $\mathcal{L}_{g,m}$ defined by

$$\begin{aligned} e_\nu(M) &= M_\nu \quad \text{for } \nu = 1, \dots, m \quad ; \\ e_0(M) &= [B_g, A_g^{-1}] \dots [B_1, A_1^{-1}] M_m \dots M_1 \quad . \end{aligned} \quad (3.46)$$

If necessary, these embeddings may be lifted to the corresponding semi-direct products with the symmetry algebra.

The embeddings (3.46) provide a set of elements in $\mathcal{A}_{g,m}$

$$c_\nu^I = \kappa_I tr_q^I(M_\nu^I) \quad , \quad \nu = 0, \dots, m \quad . \quad (3.47)$$

It was shown in [3] that all of them belong to the centre of $\mathcal{A}_{g,m}$. In particular, they commute with each other. Now we are ready to define the moduli algebra.

Definition 9 (Moduli algebra) *Let \mathcal{G} be a quasi-triangular Hopf symmetry algebra, $\Sigma_{g,m}$ be a closed oriented 2-dimensional surface of genus g with m marked points and I_1, \dots, I_m be a set of m irreducible representations of \mathcal{G} assigned to the marked points. The moduli algebra $\mathcal{M}_{g,m}^{\{I_\nu\}}$ is defined by these data as a quotient of the invariant algebra $\mathcal{A}_{g,m}$,*

$$\mathcal{M}_{g,m}^{\{I_\nu\}} = \mathcal{A}_{g,m} / \{\Phi^0(M_0), \Phi^{I_\nu}(M_\nu), \nu = 1, \dots, m\}. \quad (3.48)$$

Here 0 labels the trivial representation of \mathcal{G} . The moduli algebra $\mathcal{M}_{g,m}^{I_\nu}$ inherits the $$ -operation and the positive integration functional ω from $\mathcal{A}_{g,m}$.*

In fact, relations Φ^I are proper quantum counterparts of fixing the eigenvalues of the corresponding quantum holonomy. In particular, the set of relations Φ^0 is equivalent to $M^I = \kappa_I^{-1} e^I$ for any I . The scalar factor κ_I gives a ‘quantum correction’ to the classical flatness condition $M^I = e^I$.

3.5 The finite-dimensional case

As we already mentioned, we are mostly concerned with the case of q being a root of unity. Then one can not view the moduli algebra as a deformation of the algebra of functions on the moduli space. Instead, one can reverse the logic and reinterpret the definition of the graph algebra. The latter is defined by choosing a Riemann surface with marked points, a ribbon Hopf $*$ -algebra and a set of representations of this algebra, one representation for each marked point. The main ingredient in these data is the ribbon Hopf algebra. Instead of looking what happens to the the moduli algebra at roots of unity we look at the symmetry Hopf algebra, define it at roots of unity and thus induce a new definition of the moduli algebra. Here we follow this strategy. However, the relation between the moduli algebras at generic q and at roots of unity still needs to be clarified.

The first important observation is that at roots of unity quantum universal enveloping algebras have a big centre [13]. A natural object is a quotient over certain central relations which is already finite dimensional [31]. This is a motivation to consider symmetry Hopf algebra with only finite number of irreducible representations.

To ensure the positivity of ω (see Subsection 3.3) we require the quantum dimensions of all irreducible representations to be strictly positive

$$d_I > 0 \quad \text{for all } I. \quad (3.49)$$

In fact, this requirement may be satisfied only at roots of unity. Let us remark that there are still indecomposable representations with vanishing quantum dimensions. We will deal with them later in this subsection.

As the number of representations is finite, one can introduce a normalization constant

$$\mathcal{N} \equiv \left(\sum_K d_K^2 \right)^{-1/2} < \infty. \quad (3.50)$$

It is useful to have a matrix S^{IJ} which differs from s^{IJ} by this scalar factor:

$$S_{IJ} \equiv \mathcal{N}(tr_q^I \otimes tr_q^J)(R'R) \quad . \quad (3.51)$$

We assume that *the matrix S is invertible*. A number of standard properties of S can be derived from the invertibility (and properties of the ribbon Hopf- $*$ -algebra). We list them here without further discussion. Proofs can be found e.g. in [22].

$$\begin{aligned} S_{IJ} &= S_{JI} \quad , \quad S_{0J} = \mathcal{N}d_J \quad , \\ \sum_J S_{IJ} \overline{S_{KJ}} &= \delta_{IK} \quad , \quad \sum_J S_{IJ} S_{JK} = C_{IK} \quad , \\ \sum_K N_K^{IJ} S_{KL} &= S_{JL} S_{IL} (\mathcal{N}d_L)^{-1} \end{aligned} \quad (3.52)$$

with $C_{IJ} = \mathcal{N}_0^{IJ}$. For the relations in the second line, the existence of an inverse of S is obviously necessary. Invertibility of S is also among the defining features of a modular Hopf-algebra in [38]. The last equation in the set (3.52) is usually referred to ‘diagonalization’ of fusion rules [42].

In the finite-dimensional situation one can consider certain linear combinations χ^K of the c^I ,

$$\chi^K = \mathcal{N}d_K S_{KI} c^{\bar{I}} \quad .$$

Here $\mathcal{N} = (\sum d_I^2)^{-1/2}$ and S_{KI} are components of the S -matrix (3.51). The projectors χ^K are central, orthogonal projectors, i.e. $(\chi^K)^* = \chi^K$ and $\chi^K \chi^L = \delta_{K,L} \chi^K$ (see [3]). They represent characteristic functions for the 1-dimensional ideals in the Verlinde algebra corresponding to the representations considered in the previous subsection.

One serious technical problem which arises when we consider quantum universal enveloping algebras at roots of unity is the fact that they loose semi-simplicity. In particular, finite-dimensional Hopf algebras under discussion are not semi-simple. This problem may be cured in two different ways. One way is to work with non semi-simple algebras. Then the resulting moduli algebra is expected to have a big ideal formed by functions which include matrix elements of indecomposable representations. If one wants to introduce the moduli algebra as a $*$ -algebra this ideal should be factored out. We refer to this operation as *truncation*.

Another way is to force the universal enveloping algebra to be semi-simple [33]. Technically, one moves to the class of quasi-Hopf algebras and relaxes the axiom

$$\Delta(\epsilon) = \epsilon \otimes \epsilon \quad . \quad (3.53)$$

This defines a class of weak quasi-Hopf algebras. Then a non semi-simple Hopf algebra may be replaced by a weak quasi-Hopf algebra in the following way. One factors out all the elements which vanish in all irreducible representations. The resulting object is by definition semi-simple. All its representations are completely

reducible. In the case of quantized universal enveloping algebras these are so called physical representations related to Conformal Field Theory. New semi-simple symmetry algebras are also called *truncated*. They do not satisfy the axioms of the Hopf category. In particular, the co-multiplication still may be defined but it is not co-associative. We refer the reader to the original paper [33] for a more detailed account. It is a conceivable conjecture that looking at the moduli algebras corresponding to truncated quantum symmetries is equivalent to dealing with truncated moduli algebras defined by a non semi-simple quantum symmetry.

Admitting weak quasi-Hopf algebras we have to prove that moduli algebras may be defined by these data. This has been done in [2], [3]. The qualitative difference is that the graph algebra now is only quasi-associative. Indeed, it is designed as an algebra of the objects covariant with respect to the symmetry action. As the co-multiplication of the symmetry algebra is quasi-co-associative, the multiplication of tensors is forced to be quasi-associative. However, the moduli algebra is always an associative algebra.

All our results are valid for truncated weak quasi-Hopf symmetry algebras. This includes the most interesting cases of $U_q(\mathfrak{g})$ at roots of unity which correspond to quantization of the Chern-Simons theory for integer values of k and for the compact Lie group G . However, for pedagogical reasons we work throughout the paper with the unrealistic case of a semi-simple Hopf algebra with finite number of irreducible representations. A more sophisticated version of the same calculations goes through for the case of weak quasi-Hopf algebras. In the end of the paper we comment on the most important changes in the consideration.

4 Summary of Results

4.1 Representation theory of the moduli algebra

The moduli algebra $\mathcal{M}_{g,m}^{\{I_\nu\}}$ corresponding to the truncated universal enveloping algebra $U_q(\mathfrak{g})$ is supposed to coincide with the algebra of observables of the Chern-Simons theory. Naturally, its $*$ -representations may be considered as candidates for the role of the Hilbert space in this model.

Assuming that we construct the moduli algebra starting from a semi-simple quasi-triangular (quasi)-Hopf algebra with only finite number of representations we arrive at the following result.

Theorem 10 (Representations of the moduli algebra) *For any set of representations I_1, \dots, I_m assigned to the marked points there exists a unique irreducible $*$ -representation of the moduli algebra $\mathcal{M}_{g,m}^{\{I_\nu\}}$ which acts in the space*

$$W_g^0(I_1, \dots, I_m) = \text{Inv}(V^{I_1} \otimes \dots \otimes V^{I_m} \otimes \mathfrak{R}^{\otimes g}) \quad (4.54)$$

$$\text{where} \quad \mathfrak{R} = \bigoplus_I V^I \otimes V^I .$$

Here Inv stays for invariant subspace with respect to the natural action of the symmetry algebra.

It is remarkable that the moduli algebra has a unique representation. Thus, it is identified with the full matrix algebra with the natural $*$ -operation and may be regarded as an algebra of observables of some quantum mechanical system with a finite-dimensional space of states. Apparently, this is the case of the Chern-Simons theory in the Hamiltonian formulation.

The space \mathfrak{K} which enters the definition of $W_g^0(I_1, \dots, I_m)$ is an analog of the regular representation of a finite or a compact Lie group.

We shall show explicit formulas for the action of $\mathcal{M}_{g,m}^{\{I_\nu\}}$ in the representation (4.54). Let us only remark that there is an important difference between the moduli algebras of zero and nonzero genus. The first ones involve only R -matrices in the expressions for the matrix elements of their representations. However, when the genus of the surface is nontrivial, the knowledge of Clebsch-Gordon maps is required.

4.2 The action of the mapping class group on the moduli algebra

There is an important structure on the moduli space which we did not touch before. The moduli space of flat connections on a surface $\Sigma_{g,m}$ carries the action of the pure mapping class group $PM(g, m)$ of the surface. The pure mapping class group is a subgroup of the mapping class group $M(g, m)$ which preserves the order of marked points. $PM(g, m)$ acts by automorphisms of the fundamental group of the surface. This action lifts to $Hom(\pi, G)$ as

$$\rho^\eta(x) = \rho(x^\eta) \quad \text{for all } x \in \pi_1(\Sigma_{g,m}) \quad . \quad (4.55)$$

Here ρ is a representation of π in G , x is an element of the fundamental group and η is an element of the mapping class group. As η defines an automorphism of π , this action descends to the moduli space.

In the course of quantization symmetries are usually very important as they give us guidelines which features of the classical theory should be preserved by quantization. The action of the mapping class group on the moduli space of flat connections preserves the symplectic structure. So, we should expect that this action lifts to the quantized algebra of functions on the moduli space. This is indeed the case. We need some more notations to describe this action.

The pure mapping class group may be generated by so called Dehn twists. A Dehn twist corresponds to a circle on a Riemann surface. The mapping class group transformation includes cutting the surface along this fixed circle, relative rotation of the boundaries of the cut by the angle of 2π and gluing the sides of the cut back together. Thus one defines a smooth mapping of the surface into itself which does not belong to the connected component of the identical mapping.

As a first step we define a Verlinde subalgebra in the moduli algebra for each circle on a Riemann surface. A circle on a surface (or, more exactly, its homotopy type) defines a conjugacy class in the fundamental group. Let us take any element x of this conjugacy class and represent it as a word in the generators of the standard basis l_ν, a_i, b_i . As an example let us pick up an element

$$x = l_1 b_1 a_1 \ . \quad (4.56)$$

Now we define a bunch of quantum holonomy matrices via

$$X^I = \kappa_I^{-2} M_1^I B_1^I A_1^I \ . \quad (4.57)$$

Here I is as usual a representation of the symmetry algebra. In the standard way we define the generators of the Verlinde algebra

$$c^I(x) = \kappa_I \text{tr}_q X^I \quad (4.58)$$

corresponding to the circle x . One can easily repeat this procedure for an arbitrary circle on the surface. The choice of the representative in the conjugacy class appears to be irrelevant for the definition of c^I due to the properties of the q -trace. We refer to Section 9 for the general rule of counting extra κ^I factors.

The last ingredient which we need is a particular element in the Verlinde algebra defined as

$$\hat{h}(x) = \sum_I v_I^{-1} \chi^I(x) \ . \quad (4.59)$$

Here projectors χ^I are constructed of c^I as in the previous section.

We collect the main results concerning the action of the mapping class group in the following theorem.

Theorem 11 *The moduli algebra $\mathcal{M}_{g,m}^{\{I_\nu\}}$ corresponding to a surface of genus g with m marked points carries a natural action of the pure mapping class group $PM(g, m)$ which preserves the order of the marked points. $PM(g, m)$ acts by inner automorphisms of the moduli algebra. The unitary generator of a particular Dehn twist defined by a circle x on the surface is given by $\hat{h}(x)$. This gives rise to a projective representation of the mapping class group which is unitary equivalent to the one described in [37].*

4.3 Comparison to other approaches

We can compare the Combinatorial quantization approach of this paper to two other quantization schemes.

Let us recall that the Hilbert space of the Chern-Simons theory has been identified with the space of conformal blocks in the WZW Conformal Field Theory corresponding to the same group G and with the same value of the coupling constant k [43]. The guess about the relation of the CS and WZW systems

has been explained in the framework of Geometric Quantization [9]. Technically speaking the space of conformal blocks may be characterized as a space of solutions of certain linear differential equations. In the simplest case of the 2-dimensional surface being a sphere with marked points, these equations were suggested in [30] and usually called Knizhnik-Zamolodchikov (KZ) equations.

One can notice that the dimension of the representation space (4.54) coincides with the Verlinde formula for the dimension of the space of conformal blocks. The natural isomorphism between these two spaces emerges when one considers certain asymptotics of the KZ-equations [15]. This is one of the aspects of the relation between quantum groups and Kac-Moody algebras discovered in [27]. The particular case of roots of unity has been worked out in [20]. We expect that the general results of [27, 20] imply the identification of the geometric quantization and quantum group pictures for the space of conformal blocks. However, the current status of this construction is not clear to us.

Another approach which we follow quite closely is deformation quantization. The r -matrix presentation of the Poisson brackets on the moduli space is especially designed to make deformation quantization easy. It is natural to conjecture that for generic values of the deformation parameter q the moduli algebra $\mathcal{M}_{g,m}^{\{I_\nu\}}$ provides a deformation quantization of the algebra of functions on the moduli space.

As was recently discovered [19], the deformation quantization is uniquely defined by choosing a symplectic connection on the phase space. It is an intriguing question what kind of connection on the moduli space chooses the Combinatorial quantization.

Part II

Representation Theory of the Moduli Algebra

Our basic strategy in this part on the representation theory of graph- and moduli algebras is to study very simple building blocks of the graph algebra first and then to put the pieces together for the full theory to emerge. The simple building blocks are the *loop algebra* $\mathcal{L} = \mathcal{L}_{0,1}$ (section 5) and the *AB- (or handle-) algebra* $\mathcal{T} = \mathcal{L}_{1,0}$ (section 7). A bunch of loop algebras \mathcal{L} may be combined into a *multi-loop algebra* $\mathcal{L}_m = \mathcal{L}_{0,m}$ (section 6). From this one obtains the moduli algebras associated with a punctured sphere. Section 8 concludes the representation theory of moduli algebras with a complete description for arbitrary genus g . The relation of this theory with representations of the mapping class group is explained in Section 9.

5 The Loop Algebra and its Representations

This section contains an extensive treatment of the *loop algebra* \mathcal{L} which will be the most fundamental building block in all the subsequent discussion. The main aim is to develop a complete representation theory for \mathcal{L} . In passing we note some results on Gauss decompositions in the third subsection.

5.1 The loop algebra \mathcal{L}

The *loop algebra* \mathcal{L} already appeared in Section 3.2 and 3.4 as a special example of graph algebras, namely $\mathcal{L}_{0,1}$. It is generated by matrix elements of the monodromies $M^I \equiv M_1^I \in \text{End}(V^I) \otimes \mathcal{L}$. In this simple case of a graph algebra, monodromies only have to obey *functoriality*,

$$M^I R^{IJ} M^J = \sum C^a[IJ|K]^* M^K C^a[IJ|K] . \quad (5.1)$$

Such relations were discussed at length in Section 3.2. For the covariance properties of monodromies M^I and the action of the $*$ -operation on $\mathcal{S}_{0,1} \supset \mathcal{L}$, the reader is referred to Sections 3.2, 3.3.

To motivate the results we are about to see in this section, let us pick up some traces that were laid in the first part. It was already noticed in Section 3.2 that *functoriality on the loop* (eq. (5.1)) determines the following exchange relations for the monodromy

$$(R')^{IJ} M^I R^{IJ} M^J = M^J R^{IJ} M^I (R')^{IJ} . \quad (5.2)$$

Relations of this form were found to describe the quantum enveloping algebras of simple Lie algebras [36], which are our main examples for the quantum symmetry \mathcal{G} . Thus – following the ideology of [18] – one expects that the deeper investigation to be carried out below will reveal an isomorphism between \mathcal{L} and \mathcal{G} (at least up to some subtleties). This expectation gains further support from our discussion in Sections 3.4 and 3.5 where we found that the following elements

$$\chi^K = \mathcal{N} d_K S_{KI} c^I = \mathcal{N} d_K \kappa_I S_{KI} \text{tr}_q^I(M^I)$$

form a set of orthogonal projectors in the center of the loop algebra. Since these *characteristic projectors* χ^K are labeled by the same index as the irreducible representations of \mathcal{G} , a close correspondence between representations of \mathcal{G} and \mathcal{L} is quite plausible.

These remarks, however, have to be taken with a little grain of salt. For the isomorphism of \mathcal{G} and \mathcal{L} to hold, we have to restrict ourselves to the unrealistic case of a finite-dimensional algebra \mathcal{G} without truncation. If the tensor product of representations of the symmetry algebra \mathcal{G} is truncated, the linear dimension of \mathcal{L} is strictly smaller than the dimension of \mathcal{G} , thus making an isomorphism of the two spaces impossible. Still a close relation between their representation theories

will persist so that the lesson we learn here in the non-truncated case is not in vain. We will return to this discussion only in Section 10 when we explain the adjustments which are required to treat truncated structures.

5.2 Representation theory of the loop algebra \mathcal{L}

Now let us turn to our the main result in this section. We wish to consider the representation theory of \mathcal{L} . Since we suspect a close relation between \mathcal{G} and \mathcal{L} , it should be possible to construct representations of \mathcal{L} in the same spaces V^I in which we already have representations τ^I of the symmetry algebra \mathcal{G} . The following theorem gives a concrete formulation of this idea.

Theorem 12 (Representations of the loop algebra) *The loop algebra \mathcal{L} has a series of representations D^I realized in the representation spaces V^I of the underlying quasitriangular Hopf algebra \mathcal{G} . In such a representation, the generators of \mathcal{L} can be expressed as*

$$D^I(M^J) = (\kappa_J)^{-1}(R'R)^{JI} \quad .$$

D^I extends to a $*$ -representation of the semi-direct product $\mathcal{S}_{0,1} \equiv \mathcal{L} \times_S \mathcal{G}$ by means of the formula

$$D^I(\xi) = \tau^I(\xi) \quad \text{for all } \xi \in \mathcal{G} \quad .$$

Compatibility with the $*$ -operation on $\mathcal{S}_{0,1}$ means in particular that $D^I(M^*) = (D^I(M))^*$ for all $M \in \mathcal{L}$.

PROOF: To prove consistency with the multiplication rule (5.1) let us evaluate the l.h.s. of (5.1) in the representation D^L

$$\begin{aligned} D^L(M^1 R^I R^{IJ} M^2 J) &= (\kappa_I \kappa_J)^{-1} (R'_{13} R_{13} R_{12} R'_{23} R_{23})^{IJL} \\ &= (\kappa_I \kappa_J)^{-1} (R'_{13} R'_{23} R_{12} R_{13} R_{23})^{IJL} \\ &= (\kappa_I \kappa_J)^{-1} (R_{12} R'_{23} R'_{13} R_{13} R_{23})^{IJL} \\ &= (\kappa_I \kappa_J)^{-1} (R_{12} (\Delta \otimes id) (R'R))^{IJL} \quad . \end{aligned}$$

We used the Yang Baxter equation for R twice and inserted quasi-triangularity in the last line. Now one proceeds with the help of equation (3.6).

$$\begin{aligned} &= (\kappa_K)^{-1} \sum C^a[IJ|K]^* C^a[IJ|K] ((\Delta \otimes id)(R'R))^{IJL} \\ &= \sum (\kappa_K)^{-1} C^a[IJ|K]^* (R'R)^{KL} C^a[IJ|K] \\ &= D^L \left(\sum C^a[IJ|K]^* M^K C^a[IJ|K] \right) \quad . \end{aligned}$$

To see that D^I can be extended to $\mathcal{S}_{0,1}$ we have to check consistency of D^I with the covariance properties (3.34) of monodromies. Acting with D^I on eq. (3.34) we obtain

$$(\tau^J \otimes \tau^I)(\Delta(\xi))\kappa_J^{-1}(R'R)^{JI} = \kappa_J^{-1}(R'R)^{JI}(\tau^J \otimes \tau^I)(\Delta(\xi))$$

which holds due to the standard intertwining property of R . So let us finally show that D^I is a $*$ -representation. Because $(M^J)^{-1}$ is represented by $\kappa_J((R'R)^{-1})^{JI}$ one gets

$$\begin{aligned} D^I((M^J)^*) &= \kappa_J \kappa_I^{-1} R^{JI} (R^{-1}(R')^{-1})^{JI} (R^{-1})^{JI} \kappa_I \\ &= \kappa_J ((R')^{-1} R^{-1})^{JI} = (\kappa_J^{-1} (R'R)^{JI})^* \\ &= (D^I(M^J))^* \quad . \end{aligned}$$

This concludes the proof of the proposition.

Having constructed a series of representations of \mathcal{L} , it is instructive to look at the central elements c^J (given by eq. (3.42)) and evaluate them in these representations. Using the definition (3.51) of the matrix S_{JI} we can express the value of the central element c^J in the representation D^I as follows

$$D^I(c^J) = \frac{S_{JI}}{\mathcal{N}d_I} \quad .$$

Evaluation of the elements $\chi^K = \mathcal{N}d_K S_{K\bar{J}} c^J$ shows that they are characteristic projectors for our representations,

$$D^I(\chi^K) = \frac{d_K}{d_I} S_{KJ} S_{JI} = \delta_{K,I} \quad . \quad (5.3)$$

Actually the χ^K provide a complete set of minimal central projectors in \mathcal{L} :

Lemma 1 *The set of representations $\{D^I\}$ is faithful on \mathcal{L} , i.e. for any nonzero element $X \in \mathcal{L}$ there is at least one label I such that $D^I(X)$ is nonzero. In absence of truncation this implies that the representations D^I are irreducible.*

PROOF: Let δ_I denote the dimension of V^I . In order to prove the irreducibility we have to investigate the space $\mathcal{D}^I \subset \text{End}(V^I)$ obtained as the image of \mathcal{L} under D^I . The assertion of the lemma holds, if \mathcal{D}^I has the dimension δ_I^2 , i.e. if \mathcal{D}^I is the full matrix algebra on V^I . It will be fundamental to notice that the space $\text{End}(V^I)$ carries a representation ad^I of the symmetry Hopf-algebra \mathcal{G} ,

$$ad^I(\xi)b^I \equiv \sum \tau^I(\xi_\sigma^2) b^I \tau^I(\mathcal{S}(\xi_\sigma^1)) \quad \text{for all } b^I \in \text{End}(V^I) \quad .$$

With respect to this action, the space $\text{End}(V^I)$ decomposes into a direct sum of subspaces one for every irreducible representation in the decomposition of the tensor product

$$(\tau^{\bar{I}} \boxtimes \tau^I) \cong \bigoplus N_K^{\bar{I}} \tau^K \quad .$$

The corresponding irreducible subspaces $S^I(K, a)$ of $End(V^I)$ are labeled by pairs K, a such that $C^a[I\bar{I}|K] \neq 0$. Now let us fit the space \mathcal{D}^I of representation matrices of \mathcal{L} into this picture. Elements in \mathcal{D}^I are obtained from the components of

$$D^I(M^J) = \kappa_J^{-1}(R'R)^{JI} \quad ,$$

where J runs through all possible labels. If the standard intertwining relation $\Delta(\xi)R'R = R'R\Delta(\xi)$ is written in the somewhat non-standard form

$$\sum (e \otimes \xi_\sigma^2)R'R(e \otimes \mathcal{S}(\xi_\sigma^1)) = \sum (\mathcal{S}(\xi_\sigma^1) \otimes e)R'R(\xi_\sigma^2 \otimes e) \quad ,$$

one concludes that $\mathcal{D}^I \subset End(V^I)$ is invariant under the action ad^I of the algebra \mathcal{G} . So the before mentioned decomposition of $End(V^I)$ induces a decomposition of the subspace $\mathcal{D}^I \subset End(V^I)$.

Elements in the irreducible subspaces $S^I(K, a) \cap \mathcal{D}^I$ of $End(V^I)$ are constructed from representations matrices of the loop algebra \mathcal{L} as

$$D^I(C[I\bar{I}|0]M^J(R')^{I\bar{I}}C^a[I\bar{I}|K]^*) \quad . \quad (5.4)$$

We wish to show that for every pair K, a such that $C^a[I\bar{I}|K] \neq 0$ at least one element of the form (5.4) is nonzero. Equivalently, we have to find one set of labels J, L, b so that the maps $E_{ab}^{IJ}(K|L) : V^K \mapsto V^L$ defined by

$$E_{ab}^{IJ}(K|L) \equiv C^b[\bar{J}J|L]D^I(C[I\bar{I}|0]M^J(R')^{I\bar{I}}C^a[I\bar{I}|K]^*)(R')^{JJ}C[\bar{J}J|0]^*$$

do not vanish. A simple calculation shows

$$\tau^L(\xi)E_{ab}^{IJ}(K|L) = E_{ab}^{IJ}(K|L)\tau^K(\xi) \quad .$$

It follows with the help of Schurs' lemma that $E_{ab}^{IJ} = \delta_{K,L}e_{ab}^{IJ}(K)$. The complex number $e_{ab}^{IJ}(K)$ determines whether the map $E_{ab}^{IJ}(K|L)$ vanishes or not.

In conclusion we find that the space \mathcal{D}^I is equal to $End(V^I)$, if and only if for every pair K, a such that $C^a[I\bar{I}|K] \neq 0$ there is a pair J, b such that $e_{ab}^{IJ}(K)$ is nonzero. In fact, if the stated condition is satisfied, it guarantees the existence of at least one element in $S^I(K, a) \cap \mathcal{D}^I$. Considering that \mathcal{G} acts on both $S^I(K, a)$ and \mathcal{D}^I , we can conclude $S^I(K, a) \cap \mathcal{D}^I = S^I(K, a)$ so that $\mathcal{D}^I = End(V^I)$ follows from $\bigoplus_{K,a} S^I(K, a) = End(V^I)$.

A long but straightforward calculation indeed shows that

$$\sum_{b,J} e_{ab}^{IJ}(K)(e_{ab}^{IJ}(K))^* v_J d_J^2 \neq 0 \quad .$$

This means that sufficiently many numbers $e_{ab}^{IJ}(K)$ are nonzero and establishes the irreducibility of D^I .

The whole set of representations D^I of \mathcal{L} maps the loop algebra \mathcal{L} to the algebra $\bigoplus_I End(V^I)$. Since \mathcal{L} is spanned by the matrix elements of monodromies $M^J \in End(V^J) \otimes \mathcal{L}$ it has the dimension $\sum_J \delta_J^2$. The latter coincides with the dimension of the space $\bigoplus_I End(V^I)$ of representation matrices so that the set $\{D^I\}$ is faithful.

5.3 Gauss decomposition and loop-symmetry isomorphism

The previous lemma has two prominent consequences which we would like to mention in passing, even though they will not be used later. They can be regarded as a refinement of the technique developed by Faddeev, Reshetikhin and Takhtajan in [18]. First we can exploit Lemma 1 to introduce the quantum Gauss decomposition for the matrix generators of the loop algebra. All representations D^I of \mathcal{L} are irreducible so that there are elements $M_{\pm}^J \in \text{End}(V^J) \otimes \mathcal{L}$ with the property

$$D^I(M_+^J) = (R')^{JI} \quad , \quad D^I(M_-^J) = (R^{-1})^{JI} \quad .$$

The elements M_{\pm}^J are clearly invertible, i.e. there exist elements $(M_{\pm}^J)^{-1}$ such that $M_{\pm}^J (M_{\pm}^J)^{-1} = e^J = (M_{\pm}^J)^{-1} M_{\pm}^J$. If we evaluate the product $(\kappa_J)^{-1} M_+^J (M_-^J)^{-1}$ in the representation D^I , it is found to agree with the representation matrix of M^J ,

$$D^I(\kappa_J^{-1} M_+^J (M_-^J)^{-1}) = \kappa_J^{-1} (R'R)^{JI} = D^I(M^J) \quad .$$

From faithfulness of the representation theory (Lemma 1) we conclude that the matrix generators satisfy $\kappa_J^{-1} M_+^J (M_-^J)^{-1} = M^J$.

Corollary 13 (Gauss decomposition) *In absence of truncation there exist elements $M_{\pm}^J \in \text{End}(V^J) \otimes \mathcal{L}$ such that*

$$M^J = \kappa_J^{-1} M_+^J (M_-^J)^{-1}, \quad (5.5)$$

where $(M_-^J)^{-1} \in \text{End}(V^J) \otimes \mathcal{L}$ is the inverse of M_-^J .

A second consequence of Lemma 1 was already motivated by our discussion in the first subsection.

Corollary 14 (Loop-symmetry isomorphism) *In absence of truncation the symmetry Hopf-algebra \mathcal{G} is isomorphic (as a Hopf- $*$ -algebra) to the algebra \mathcal{L} generated by matrix elements of $M^I \in \text{End}(V^I) \otimes \mathcal{L}$ subject to the relations*

$$M^I R^{IJ} M^J = \sum C^a [IJ|K]^* M^K C^a [IJ|K] \quad ,$$

and supplied with the following co-product, co-unit, antipode and $*$ -operation

$$\begin{aligned} \Delta(M^I) &= \kappa_I^{-1} M_+^I \tilde{M}^I (M_-^I)^{-1} \quad , \\ \epsilon(M^I) &= \kappa_I^{-1} e^I \quad , \\ \mathcal{S}(M_+^I) &= (M_+^I)^{-1} \quad , \quad \mathcal{S}(M_-^I) = (M_-^I)^{-1} \quad , \\ (M^I)^* &= \sigma_{\kappa}((M_-^I)^{-1} (M^I)^{-1} M_-^I) \quad . \end{aligned}$$

Here M_{\pm}^I are the Gauss components of M^I and σ_{κ} is conjugation with κ regarded as an element in \mathcal{L} . On the right hand side of the first relation, the factors are elements in $\text{End}(V^I) \otimes \mathcal{L} \otimes \mathcal{L}$. $M_+^I, (M_-^I)^{-1}$ are supposed to have trivial entry in the last component while $\tilde{M}^I \equiv \sum m_{\sigma} \otimes e \otimes M_{\sigma}$ with e being the unit in \mathcal{L} and $M^I = \sum m_{\sigma} \otimes M_{\sigma} \in \text{End}(V^I) \otimes \mathcal{L}$.

PROOF: To understand the formulas for the action of the co-product, co-unit etc., one has to evaluate them in the representations D^I . On representation spaces they turn into standard relations for the R -matrix, co-unit ϵ etc. of the quantum symmetry \mathcal{G} . Faithfulness of the representation theory allows to transport the results back to the level of algebras \mathcal{L}, \mathcal{G} .

6 The Moduli Algebra on a Sphere with Marked Points

We will now extend our analysis to some kind of *multi-loop algebra*. In the terminology of Part 1, the main actor of this section is the graph algebra $\mathcal{L}_{0,m}$ which is assigned to an m -punctured sphere. This leads us to our simplest examples of moduli algebras. We will be able to give a complete description of their representations theory. The section also contains a proof of the first *pinching theorem* that was used in [3] to normalize the Chern-Simons measure ω_{CS} .

6.1 The graph algebra \mathcal{L}_m

A full definition of the graph algebra $\mathcal{L}_m = \mathcal{L}_{0,m}$ was given in Section 3.2. It is generated by matrix elements of a family of monodromies $M_\nu^I, \nu = 1, \dots, m$. In addition to the usual functoriality, these monodromies are subject to the following exchange relations,

$$(R^{-1})^{IJ} M_\nu^I R^{IJ} M_\mu^J = M_\mu^J (R^{-1})^{IJ} M_\nu^I R^{IJ} \quad \text{if } \nu < \mu . \quad (6.1)$$

As one can see, the graph algebra \mathcal{L}_m contains a bunch of loop algebras. For fixed subscript ν , the matrix elements of M_ν^I generate a subalgebra $\mathcal{L}(M_\nu)$ of \mathcal{L}_m which is isomorphic to the loop algebra \mathcal{L} . It was suggested in Section 3.4 to construct the elements

$$c_\nu^I = \kappa_I \text{tr}_q^I(M_\nu^I) . \quad (6.2)$$

For fixed index ν , they certainly generate a fusion algebra and commute with every element in $\mathcal{L}(M_\nu)$. Moreover, using the equation $\text{tr}_q^I(M_\nu^I) = \text{tr}_q^I[(R^{-1})^{IJ} M_\nu^I R^{IJ}]$ we infer from eq. (6.1) that

$$c_\nu^I M_\mu^J = M_\mu^J c_\nu^I \quad \text{for } \nu < \mu$$

and the same for $\mu > \nu$. This means that the c_ν^I provide a large family of central elements in the graph algebra \mathcal{L}_m . Needless to say that we can pass to characteristic projectors χ_ν^K with the same transformation that was used in Section 3.5. From these remarks we certainly expect representations of the graph algebra \mathcal{L}_m to be labeled by tuples (I_1, \dots, I_m) . This will be confirmed in the next subsection.

6.2 Representation theory of the graph algebra \mathcal{L}_m

Let us turn to the representation theory of \mathcal{L}_m . Our strategy is to construct the representations in tensor products

$$\mathfrak{S}(I_1, \dots, I_m) = V^{I_1} \otimes \dots \otimes V^{I_m} \quad (6.3)$$

of the representations spaces of the underlying Hopf algebra \mathcal{G} . To state the formulas we introduce the notation $D_\nu^{I_\nu}$ for the representation D^{I_ν} of the ν^{th} copy $\mathcal{L}(M_\nu) \subset \mathcal{L}_m$ of the loop algebra on the ν^{th} factor in the tensor product (6.3), i.e. for every $X \in \mathcal{L}(M_\nu)$,

$$D_\nu^{I_\nu}(X) = id_{I_1} \otimes \dots \otimes id_{I_{\nu-1}} \otimes D^{I_\nu}(X) \otimes id_{I_{\nu+1}} \otimes \dots \otimes id_{I_m} .$$

Given a set of labels I_1, \dots, I_m , it is convenient to use $\iota_\nu, \nu = 1, \dots, m$, as a shorthand for the representations $\iota_1 = \epsilon$ and

$$\iota_\nu(\xi) = (\tau^{I_1} \boxtimes \dots \boxtimes \tau^{I_{\nu-1}})(\xi) \otimes id_{I_\nu} \otimes \dots \otimes id_{I_m} \quad (\nu \geq 2)$$

of the Hopf algebra \mathcal{G} on the tensor product $V^{I_1} \otimes \dots \otimes V^{I_m}$. $(\tau^{I_1} \boxtimes \dots \boxtimes \tau^{I_{\nu-1}})$ is the ordinary tensor product of representations τ^{I_1} through $\tau^{I_{\nu-1}}$ of \mathcal{G} . The representation $\iota = \iota_{m+1}$ coincides with the natural action of \mathcal{G} in the space $\mathfrak{S}(I_1, \dots, I_m)$. With these notations we are prepared to define representations of \mathcal{L}_m .

Theorem 15 (Representations of the algebra \mathcal{L}_m) *The algebra \mathcal{L}_m has a series of representations D^{I_1, \dots, I_m} realized in the tensor product (6.3) of representation spaces of the underlying quasi-triangular Hopf algebra \mathcal{G} . In such a representation the generators of \mathcal{L}_m can be expressed as*

$$D^{I_1, \dots, I_m}(M_\nu^J) = (\tau^J \otimes \iota_\nu)(R') D_\nu^{I_\nu}(M_\nu^J) (\tau^J \otimes \iota_\nu)((R')^{-1}) .$$

These representations extend to the semi-direct product $\mathcal{S}_m \equiv \mathcal{L}_m \times_S \mathcal{G}$ with the help of

$$D^{I_1, \dots, I_m}(\xi) = \iota(\xi) \quad \text{for all } \xi \in \mathcal{G} .$$

The set of representations $\{D^{I_1, \dots, I_m}\}$ is faithful on \mathcal{L}_m . In absence of truncation this implies that the representations D^{I_1, \dots, I_m} are irreducible.

A more explicit formula for the action of M_ν^J involves the elements $K_n \in \mathcal{G}^{\otimes(n+1)}$ with $K_1 = e \otimes e$ and

$$K_n = (K_{n-1} \otimes e) R'_{1n} \quad \text{for } n \geq 2 .$$

Using the definition of ι_ν , $D_\nu^{I_\nu}$ and quasi-triangularity one may derive that

$$D^{I_1, \dots, I_m}(M_\nu^J) = (\kappa_J)^{-1} (K_\nu R'_{1(\nu+1)} R_{1(\nu+1)} K_\nu^{-1} \otimes e^{(m-\nu)})^{J I_1 \dots I_m} ,$$

where $e^{(n)}$ is the unit element in $\mathcal{G}^{\otimes n}$.

We are certainly interested in the $*$ -properties of the representations D^{I_1, \dots, I_m} . They are described by the following proposition.

Proposition 16 (Scalar product for $\mathfrak{S}(I_1, \dots, I_m)$) *Suppose that τ, τ' are two $*$ -representations of the Hopf algebra \mathcal{G} on Hilbert spaces V, V' . With (\cdot, \cdot) denoting the standard scalar product on $V \otimes V'$, the formula*

$$\langle v_1, v_2 \rangle \quad \equiv \quad (v_1, (\tau \boxtimes \tau')(R\eta)v_2) \quad ,$$

with $\eta \equiv \Delta(\kappa)(\kappa^{-1} \otimes \kappa^{-1})$

defines a (positive definite) scalar product for elements $v_1, v_2 \in V \otimes V'$. The tensor product $(\tau \boxtimes \tau')$ is a $$ -representation of \mathcal{G} with respect to $\langle \cdot, \cdot \rangle$. Iteration gives a scalar product $\langle \cdot, \cdot \rangle$ on $\mathfrak{S}(V_1, \dots, V_m)$. With respect to this scalar product, the D^{I_1, \dots, I_m} are $*$ -representations.*

Scalar products of this type have been proposed by Durhuus et al. [16]. They are motivated by the fact that tensor products $\tau \boxtimes \tau'$ of $*$ -representations are incompatible with the $*$ -operation when we use the scalar product (\cdot, \cdot) on $V \otimes V'$ to give sense to $((\tau \boxtimes \tau')(\xi))^*$. To avoid confusion we would like to stress that the two different scalar products (\cdot, \cdot) and $\langle \cdot, \cdot \rangle$ furnish two different notions of “adjoint” for linear maps $X : V \otimes V' \mapsto V \otimes V'$. The adjoint with respect to (\cdot, \cdot) is denoted by $*$ and was used e.g. in $C^a[IJ|K]^*$. For the new adjoint provided by $\langle \cdot, \cdot \rangle$ we will occasionally employ the symbol \dagger .

PROOF: The proof of Proposition 16 and the main statements in Theorem 15 is rather standard and we can leave it as an exercise. Let us, however, give some arguments which establish the irreducibility statement in Theorem 15.

For this purpose, we count the number of linear independent elements in the image of the representation D^{I_1, \dots, I_m} and show that it is given by $\prod_{\nu} \delta_{I_{\nu}}^2 = \dim(\mathfrak{S}(I_1, \dots, I_m))^2$. We do this by induction over m . The case $m = 1$ has been dealt with in Lemma 1. So suppose that the representation D^{I_1, \dots, I_m} of the set \mathcal{L}_m is irreducible. The representations $D^{I_1, \dots, I_m, I_{m+1}}$ can be restricted to the first m monodromies. This restriction coincides with D^{I_1, \dots, I_m} acting on the first m factors of the tensor product $V^{I_1} \otimes \dots \otimes V^{I_{m+1}}$. So by assumption we already found $\delta_1 = \prod_{\nu=1}^m \delta_{I_{\nu}}^2$ linear independent maps. It is worth noticing that all the maps obtained by representing the first m monodromies act trivially on the last factor $V^{I_{m+1}}$. With this in mind, let us turn to the $(m+1)^{th}$ monodromy M_{m+1}^J . A short calculation shows that they are represented by

$$D^{I_1, \dots, I_{m+1}}(M_{m+1}^J) = (\tau^J \otimes \iota \otimes \tau^{I_{m+1}}) (R_{23}^{-1} R'_{13} R_{13} R_{23})$$

with $\iota = (\tau^{I_1} \boxtimes \tau^{I_2} \boxtimes \dots \boxtimes \tau^{I_m})$. By Lemma 1 such representation matrices account for $\delta_2 = \delta_{I_{m+1}}^2$ linear independent maps. The latter act in a very special way on the representation space. In fact, every such map is of the form

$$(\iota \otimes \tau^{I_{m+1}}) (R^{-1}(e \otimes m)R)$$

with some $m \in \mathcal{G}$.

Let us finally check that products of basis elements in the two discussed sets of representation matrices are linear independent. Thereby we will establish the existence of $\delta_1 \delta_2 = \prod_{\nu=1}^{m+1} (\delta_{I_\nu})^2$ linear independent maps in the image of the representation D^{I_1, \dots, I_m} and hence the irreducibility. So consider a basis $m_\sigma^{(1)} \otimes e^{I_{m+1}}, \sigma = 1, \dots, \delta_1$, in the space of representation matrices for the first m monodromies and similarly δ_2 linear independent maps of the form $(\iota \otimes \tau^{I_{m+1}}) \left(R^{-1}(e \otimes m_\alpha^{(2)}) R \right), \alpha = 1, \dots, \delta_2$ which come from representing the monodromies M_{m+1}^I . With these two sets of basis elements, linear relations between products are of the form

$$\sum_{\sigma, \alpha} \lambda_{\sigma, \alpha} (m_\sigma^{(1)} \otimes e^{I_{m+1}}) (\iota \otimes \tau^{I_{m+1}}) \left(R^{-1}(e \otimes m_\alpha^{(2)}) R \right) = 0 \quad .$$

Let us introduce the expansion $R^{-1} = \sum s_\sigma^1 \otimes s_\sigma^2$. We multiply the equation with $(\iota \otimes \tau^{I_{m+1}}) (R^{-1}(\mathcal{S}(s_\sigma^1) \otimes e))$ from the right and with $(\iota \otimes \tau^{I_{m+1}})(e \otimes s_\sigma^2)$ from the left and sum over σ . This results in

$$\sum_{\sigma, \alpha} \lambda_{\sigma, \alpha} (m_\sigma^{(1)} \otimes e^{I_{m+1}}) (\iota \otimes \tau^{I_{m+1}}) (e \otimes m_\alpha^{(2)}) = 0 \quad .$$

Consequently, the complex coefficients $\lambda_{\sigma, \alpha}$ have to vanish. This concludes the proof.

For further considerations we need a specific subalgebra in the graph algebra \mathcal{L}_2 .

Definition 17 (Diagonal subalgebra \mathcal{L}_2^d) *The diagonal subalgebra $\mathcal{L}_2^d \subset \mathcal{L}_2$ is defined as*

$$\mathcal{L}_2^d = \mathcal{L}_2 \sum_K \chi_1^K \chi_2^{\bar{K}} \quad .$$

Irreducible representations of the algebra \mathcal{L}_2^d are labeled by the index I which runs through the set of irreducible representations of \mathcal{G} . These representations are realized in the spaces $V^I \otimes V^{\bar{I}}$.

6.3 The moduli algebra $\mathcal{M}_m^{\{K_\nu\}}$

Before we define the moduli algebra, we want to consider the $*$ -algebra \mathcal{A}_m of invariants within the space \mathcal{L}_m (cp. Definition 6). Since \mathcal{A}_m is a subalgebra of \mathcal{L}_m , the representations D^{I_1, \dots, I_m} can be restricted and furnish representations of \mathcal{A}_m on the representation space $\mathfrak{S}(I_1, \dots, I_m)$. We denote the restricted representations by the same letter D^{I_1, \dots, I_m} . As a representation of \mathcal{A}_m , D^{I_1, \dots, I_m} are reducible, or – in other words – $D^{I_1, \dots, I_m}(\mathcal{A}_m)$ has a nontrivial commutant. Obviously, the latter contains all maps on $\mathfrak{S}(I_1, \dots, I_m)$ which represent elements

in \mathcal{G} so that invariant subspaces for the representation of \mathcal{A}_m are determined by the decomposition

$$\mathfrak{S}(I_1, \dots, I_m) = \bigoplus_J V^J \otimes W^J(I_1, \dots, I_m) \quad . \quad (6.4)$$

Here the sum runs over irreducible representations of \mathcal{G} and $W^J(I_1, \dots, I_m)$ are multiplicity spaces. The decomposition (6.4) is always possible for a semisimple symmetry algebra \mathcal{G} . Because of Proposition 16, the action of \mathcal{G} on $\mathfrak{S}(I_1, \dots, I_m)$ is consistent with the adjoint \dagger . This implies that formula (6.4) is compatible with the scalar product $\langle \cdot, \cdot \rangle$ on $\mathfrak{S}(I_1, \dots, I_m)$ and consequently the multiplicity spaces $W^J(I_1, \dots, I_m)$ come equipped with a canonical scalar product.

Let us argue that the restriction of D^{I_1, \dots, I_m} to \mathcal{A}_m is irreducible on the spaces $W^J(I_1, \dots, I_m)$. We noticed before that the set of representations $\{D^{I_1, \dots, I_m}\}$ of \mathcal{L}_m is faithful. When we restrict D^{I_1, \dots, I_m} to the subalgebra $\mathcal{A}_m \subset \mathcal{L}_m$, faithfulness survives. Now let $\delta(D_m)$ denote the dimension of the space of representation matrices of \mathcal{A}_m on the direct sum

$$\bigoplus_{I, I_1, \dots, I_m} W^I(I_1, \dots, I_m) \quad . \quad (6.5)$$

Because of faithfulness of the representation theory of \mathcal{A}_m , $\delta(D_m)$ is equal to the dimension $\delta(\mathcal{A}_m)$ of the algebra \mathcal{A}_m . The latter is easy to compute. Recall that elements in \mathcal{A}_m are obtained as linear combinations of

$$\text{tr}_q^J \left(C_1[I_1, \dots, I_m|J] M_1^{I_1} \dots M_m^{I_m} C_2[I_1, \dots, I_m|J]^* \right)$$

for arbitrary sets of labels $\{I_\nu, J\}$ and two intertwiners $C_1, C_2 : V^{I_1} \otimes \dots \otimes V^{I_m} \mapsto V^J$. So we find

$$\begin{aligned} \delta(D_m) = \delta(\mathcal{A}_m) &= \sum_{I_1, \dots, I_m, J} \left(\sum_{J_1, \dots, J_{m-2}} \sum N_{J_1}^{I_1 I_2} \dots N_J^{J_{m-2} I_m} \right)^2 \\ &= \dim \left(\bigoplus_{J, \{I_\nu\}} \text{End}(W^J(I_1, \dots, I_m)) \right) \quad . \end{aligned}$$

This result for $\delta(D_m)$ shows that every map on the space $W^J(I_1, \dots, I_m)$ appears in the image of \mathcal{A}_m under the representation D^{I_1, \dots, I_m} . As a conclusion one should keep in mind that each space $W^J(I_1, \dots, I_m)$ carries an irreducible $*$ -representation of \mathcal{A}_m . Since we are interested in the moduli algebra, we do not want to formulate this as a proposition.

Let us now pass from \mathcal{A}_m to the moduli algebras. According to our discussion in Section 3.4 a moduli algebra is prepared by implementing $m + 1$ additional (flatness-) relations. In the finite dimensional case considered here, we may describe the resulting object with the help of characteristic projectors χ^J . More

explicitly, we will need the m characteristic projectors $\chi_\nu^{K_\nu}$ that were assigned to the loop algebras $\mathcal{L}(M_\nu)$ in the first subsection. As we have seen there, these characteristic projectors are central in \mathcal{L}_m and hence also in $\mathcal{A}_m \subset \mathcal{L}_m$. In addition to the $\chi_\nu^{K_\nu}$, we will employ one more set of elements $\chi_0^K \in \mathcal{A}_m$ that is assigned to the total product $r = l_m \dots l_1$ of loops l_m through l_1 , i.e.

$$\begin{aligned} \chi_0^K &\equiv \mathcal{N} d_K S_{KI} c_0^I = \mathcal{N} d_K \kappa_K S_{KI} \text{tr}_q^I(M^I(r)) & (6.6) \\ \text{with} \quad M^I(r) &= \kappa_I^{m-1} M_m^I \dots M_1^I \end{aligned}$$

By choice of the factor κ_I^{m-1} in front of $M^I(r)$, the corresponding elements c_0^I generate a fusion algebra. While the elements χ_0^K are not central in \mathcal{L}_m , it was shown in [3] that they are *central* in \mathcal{A}_m . This will be confirmed in the discussion below.

Now we are prepared to restate Definition 9 of the *moduli algebra* $\mathcal{M}_m^{\{K_\nu\}}$ in the finite dimensional case.

Definition 18 (Moduli algebra) *The moduli algebra $\mathcal{M}_m^{\{K_\nu\}}$ of a sphere with m punctures marked by $K_\nu, \nu = 1, \dots, m$, is the $*$ -algebra*

$$\mathcal{M}_m^{\{K_\nu\}} \equiv \chi_0^0 \prod_{\nu=1}^m \chi_\nu^{K_\nu} \mathcal{A}_m \quad . \quad (6.7)$$

Here $\chi_\nu^{K_\nu}, \chi_0^0 \in \mathcal{A}_m$ are the central projectors introduced in the text preceding this definition.

To determine the representation theory of the moduli algebra we have to evaluate the characteristic projectors within the representation D^{I_1, \dots, I_m} . Let us start with $\chi_\nu^{K_\nu}, \nu = 1, \dots, m$. It is easy to see that

$$D^{I_1, \dots, I_m}(\chi_\nu^{K_\nu}) = \delta_{I_\nu, K_\nu} e^{I_1} \otimes \dots \otimes e^{I_m} \quad . \quad (6.8)$$

The reasoning is similar to the derivation of eq. (5.3) and uses that traces are invariant under conjugation with $(\tau^J \otimes \iota_\nu)(R')$. The formula (6.8) implies that the $*$ -representation D^{I_1, \dots, I_m} of the moduli algebra $\mathcal{M}_m^{\{K_\nu\}}$ on the spaces $W^J(I_1, \dots, I_m)$ is nonzero, if and only if $I_\nu = K_\nu$ for all $\nu = 1, \dots, m$.

Evaluation of χ_0^0 in the representations D^{K_1, \dots, K_m} is more difficult. From formula (6.6) we see that $\chi_0^0 = \mathcal{N}^2 d_L c_0^L$ with $c_0^L = \kappa_I \text{tr}_q^L(M^L(r))$. When c_0^L is evaluated with D^{K_1, \dots, K_m} using our explicit formulas after Theorem 15 we encounter the following expression in the argument or the q -trace tr_q^L

$$\begin{aligned} &K_m R'_{1(m+1)} R_{1(m+1)} K_m^{-1} (K_{m-1} R'_{1m} R'_{1m} K_{m-1}^{-1} \otimes e) \dots R_{12} \\ &= K_m R'_{1(m+1)} R_{1(m+1)} (R'_{1m})^{-1} R'_{1m} R'_{1m} (R'_{1(m-1)})^{-1} \dots R_{12} \\ &= (id \otimes \Delta^{(m-1)})(R' R) \end{aligned}$$

In the derivation the definition of $K_\nu \in \mathcal{G}^{\otimes \nu}$ was inserted. The result for D^{K_1, \dots, K_m} evaluated on c_0^L is

$$D^{K_1, \dots, K_m}(c_0^L) = \text{tr}_q^L((\tau^L \otimes \iota_m)(R'R)) \quad .$$

On the multiplicity spaces $W^J(K_1, \dots, K_m)$ this gets represented by

$$D^{K_1, \dots, K_m}(c_0^L)|_{W^J(K_1, \dots, K_m)} = \text{tr}_q^L((\tau^L \otimes \tau^J)(R'R)) \quad .$$

The same argument that resulted in the formula (5.3) can finally be employed to conclude

$$D^{K_1, \dots, K_m}(\chi_0^0)|_{W^J(K_1, \dots, K_m)} = \delta_{J,0} \text{id}_{W^0(K_1, \dots, K_m)} \quad .$$

So we end up with only one nonzero representation of the moduli algebra $\mathcal{M}_m^{\{K_\nu\}}$ on the space $W^0(K_1, \dots, K_m)$. Because of faithfulness of the representations theory, other representations cannot exist. We may summarize these findings in the following theorem.

Theorem 19 (Representations of the moduli algebra; genus 0) *For any set K_1, \dots, K_m labeling m points on a Riemann surface of genus 0, there is a unique irreducible *-representation of the corresponding moduli algebra $\mathcal{M}_m^{\{K_\nu\}}$ on the space $W^0(K_1, \dots, K_m)$ (defined through the decomposition (6.4)). This representation can be obtained explicitly by restricting the representation D^{K_1, \dots, K_m} of \mathcal{L}_m to the moduli algebra $\mathcal{M}_m^{\{K_\nu\}}$.*

6.4 The first pinching theorem

The different algebras $\mathcal{M}_m^{\{K_\nu\}}$ are related with each other. In fact one can construct various inclusions which are parametrized by the choice of a circle on the punctured surface. Geometrically, the inclusions corresponds to a pinching of the surface. We will explain this only for one particular pinching-circle, but the idea is more general.

To state and prove the *first pinching theorem* we need to introduce some new notations. Suppose that \mathcal{X} is a subalgebra of an algebra \mathcal{Y} . The (relative) commutant of $\mathcal{X} \subset \mathcal{Y}$ will be denoted by $\mathcal{C}(\mathcal{X}, \mathcal{Y})$.

Consider the moduli algebra $\mathcal{M}_m^{K_1, \dots, K_m}$ corresponding to a sphere with m marked points. Pick up a cycle $l = l_m l_{m-1}$ (i.e. the product of the two elementary loops l_m and l_{m-1}) and construct the fusion algebra $\mathcal{V}(l)$ assigned to l , i.e. the algebra generated by

$$c^I(l) = \text{tr}_q^I(M_m^I M_{m-1}^I) \quad .$$

We wish to investigate the commutant of $\mathcal{V}(l)$ in $\mathcal{M}_m^{K_1, \dots, K_m}$. The result is given by the following theorem.

Theorem 20 (First pinching theorem) *The commutant of $\mathcal{V}(l)$ in $\mathcal{M}_m^{K_1, \dots, K_m}$ splits into the direct sum of products of moduli algebras corresponding to $m - 1$ and 3 marked points*

$$\mathcal{C}(\mathcal{V}(l), \mathcal{M}_m^{K_1, \dots, K_m}) \cong \bigoplus_K \mathcal{M}_{m-1}^{K_1, \dots, K_{m-2}, K} \otimes \mathcal{M}_3^{\bar{K}, K_{m-1}, K_m}. \quad (6.9)$$

Here the sum runs over all classes of irreducible representations of the symmetry Hopf algebra \mathcal{G} .

In Topological Field Theory the evaluation of the commutant should be interpreted as a fusion of two marked points into one. One can imagine that we create a long neck which separates these two points from the rest of the surface. When we cut the neck, the surface splits into two pieces. The “main part” carries the rest of marked points and a new one created by the cut. The other piece has only three punctures, two of them are those that we wish to fuse and the new one appears because of the cut. Iteration of this procedure results in a product of 3-punctured spheres.

PROOF: The proof consists of two parts. First we construct an embedding Φ of the algebra on the right hand side of relation (6.9) into the moduli algebra $\mathcal{M}_m^{K_1, \dots, K_m}$. Then we show that the commutant of the image of Φ is isomorphic to the fusion algebra $\mathcal{V}(l)$. By semisimplicity, this is equivalent to the statement in the theorem.

In preparation let us observe an isomorphism between moduli algebras $\mathcal{M}_p^{\{I_\nu\}}$ and the algebras

$$\chi_0^{I_p} \prod_{\nu=1}^{p-1} \chi_\nu^{I_\nu} \mathcal{A}_{p-1} \quad (6.10)$$

which are obtained from the graph algebras \mathcal{S}_{p-1} with the help of characteristic projectors (for notations cp. last subsection). In fact, our discussion of the representation theory of moduli algebras can be applied to show that algebras (6.10) possess a unique irreducible representation on the multiplicity space $W^{I_p}(I_1, \dots, I_{p-1})$. For dimensional reasons, this space is isomorphic to the representation space $W^0(I_1, \dots, I_p)$ of $\mathcal{M}_p^{\{I_\nu\}}$ so that an isomorphism of algebras follows from Theorem 19. Alternatively, this isomorphism may be obtained from the results in [3] on the independence of moduli algebras from the choice of the graph.

Let us consider the graph algebras \mathcal{L}_{m-2} and \mathcal{L}_2 . Generators for \mathcal{L}_{m-2} will be denoted by $\tilde{M}_\nu^I, \nu = 1, \dots, m - 2$, and for \mathcal{L}_2 we use $\hat{M}_i^I, i = 1, 2$. Analogous conventions apply for other elements. In particular we will need our standard characteristic projectors $\tilde{\chi}_\nu^{K_\nu}, \nu = 0, \dots, m - 2$, in $\mathcal{A}_{m-2} \subset \mathcal{L}_{m-2}$ as well as $\hat{\chi}_i^{K_{m-2+i}}, i = 0, 1, 2$, in $\mathcal{A}_2 \subset \mathcal{L}_2$.

There is an obvious embedding $\phi : \mathcal{L}_{m-2} \otimes \mathcal{L}_2 \mapsto \mathcal{L}_m$ defined by

$$\phi(\tilde{M}_\nu^I) = M_\nu^I \quad , \quad \phi(\hat{M}_i^I) = M_{m-2+i}^I$$

for all $\nu = 1, \dots, m-2$ and $i = 1, 2$. The definition of ϕ implies that

$$\phi(\tilde{\chi}_\nu^{K_\nu}) = \chi_\nu^{K_\nu} \quad , \quad \phi(\tilde{\chi}_i^{K_{m-2+i}}) = \chi_{m-2+i}^{K_{m-2+i}}$$

where ν ranges over $1, \dots, m-2$ and $i = 1, 2$. Consequently, the map ϕ induces an embedding

$$\phi : \bigoplus_K \mathcal{M}_{m-1}^{K_1, \dots, K_{m-2}, K} \otimes \mathcal{M}_3^{\bar{K}, K_{m-1}, K_m} \mapsto \mathcal{A}_m \prod_{\nu=1}^m \chi_\nu^{K_\nu} \quad . \quad (6.11)$$

In writing this we also used the isomorphism observed in the second paragraph of this proof.

The result (6.11) is not yet strong enough. In fact we have embedded the direct sum of moduli algebras on the left hand side into an algebra that is much larger than the moduli algebra $\mathcal{M}_m^{K_1, \dots, K_m}$. Notice that the latter contains a factor χ_0^0 in its definition which does not appear on the right hand side of (6.11). So it remains to understand why the full matrix algebras

$$M(K) \equiv \mathcal{M}_{m-1}^{K_1, \dots, K_{m-2}, K} \otimes \mathcal{M}_3^{\bar{K}, K_{m-1}, K_m}$$

are embedded into the direct summand $\mathcal{M}_m^{K_1, \dots, K_m} \subset \mathcal{A}_m \prod_{\nu=1}^m \chi_\nu^{K_\nu}$. The projection into the moduli algebra $\mathcal{M}_m^{K_1, \dots, K_m}$ is furnished by the element χ_0^0 . It suffices to show that the unit element in $\phi(M(K))$ is projected to a nontrivial element of the moduli algebra. If we denote the product of loops $l_{m-2} \dots l_1$ by \hat{l} and use $\hat{l} = l_m l_{m-1}$, we can write the unit element in $\phi(M(K))$ as $\chi^K(\hat{l}) \chi^{\bar{K}}(\hat{l})$. So we wish to demonstrate that $E \equiv \chi_0^0 \chi^K(\hat{l}) \chi^{\bar{K}}(\hat{l}) \neq 0$. We do this by showing that $\omega(E) \neq 0$. With the help of Lemma 3 in [3] one obtains indeed

$$\begin{aligned} \omega(E) &= \omega(\chi_0^0 \chi^K(\hat{l}) \chi^{\bar{K}}(\hat{l})) \\ &= \sum_L \omega(\chi_0^0 \chi_0^L) = \omega((\chi_0^0)^* \chi_0^0) > 0 \quad . \end{aligned}$$

We used that $\chi_0^0 \chi_0^L = \delta_{L,0} \chi_0^0 = (\chi_0^0)^* \chi_0^0$ and positivity of the functional ω (cp. Theorem 5). According to our prior remarks we can now conclude that $\Phi \equiv \chi_0^0 \phi$ defines the desired embedding.

Elements in the fusion algebra $\mathcal{V}(l)$ over the circle $l = \hat{l}$ obviously commute with the image of Φ . We will show now that the moduli algebra $\mathcal{M}_m^{\{K_\nu\}}$ contains no other elements with this property. Once more, a comparison of dimensions is useful. Indeed, square roots of the dimensions of the matrix blocks $\mathcal{M}_{m-1}^{K_1, \dots, K_{m-2}, K} \otimes \mathcal{M}_3^{\bar{K}, K_{m-1}, K_m}$ add up to the square root of the dimension of the moduli algebra $\mathcal{M}_m^{\{K_\nu\}}$. This implies that every block is embedded with multiplicity one into the moduli algebra and hence the commutant of the image of Φ cannot contain more than the algebra of its minimal central projectors. The latter coincides with the fusion algebra $\mathcal{V}(l)$. This concludes the proof of the first pinching theorem.

7 The Handle Algebra and its Representations

Before we get to discuss surfaces of higher genus, we have to introduce one more elementary building block: the *AB- (or handle-) algebra*. It will turn out to be associated to a handle of the surface, much as a loop algebra came with every puncture. The *AB*-algebra is a graph algebra – namely the algebra $\mathcal{L}_{1,0}$ – assigned to a pair of links winding around a handle. These links correspond to the *a*- and *b*- cycles (hence the name *AB*-algebra). The main topic is again the representation theory for the *AB*-algebra in the second subsection. At the end of the section, we discuss some properties of the algebra which will be used in the next two sections.

7.1 The *AB*-algebra

Following our tradition, let us recall that the *AB*-algebra $\mathcal{T} = \mathcal{L}_{1,0}$ is generated by matrix elements of two monodromies $A^I = A_1^I, B^I = B_1^I \in \text{End}(V^I) \otimes \mathcal{T}$. As usual, the monodromies satisfy functoriality. A more characteristic feature are the exchange relations between A^I and B^J ,

$$(R^{-1})^{IJ} \overset{1}{A} R^{IJ} \overset{2}{B}^J = \overset{2}{B}^J (R')^{IJ} \overset{1}{A} R^{IJ} \quad . \quad (7.1)$$

For a complete description of $\mathcal{T} = \mathcal{L}_{1,0}$ including covariance properties and the \ast -operation on $\mathcal{S}_{1,0} = \mathcal{T} \times_S \mathcal{G}$ we refer the reader to Sections 3.2, 3.3.

We recognize two copies of the loop algebra inside the *AB*-algebra which are associated with the monodromies A^I and B^J . As before one may construct elements c^I from these monodromies. Unlike in the previous section, they turn out not to be central in the *AB*-algebra. In fact we will see shortly that \mathcal{T} has a trivial center.

The algebra \mathcal{T} is isomorphic to some well-known object. Namely, there are many ways to identify it with the quantized algebra of functions on the Heisenberg double corresponding to the symmetry Hopf algebra \mathcal{G} . The Heisenberg double is a Poisson-Lie counterpart of the cotangent bundle to a Lie group. The corresponding quantized algebra of functions is a generalization of the algebra of finite order differential operators on a Lie group. The isomorphism between the algebra \mathcal{T} and the quantized algebra of functions on the Heisenberg double is not canonical. One of the reasons for that is a wide group of automorphisms of the *AB*-algebra \mathcal{T} . They will be discussed in the last subsection.

7.2 Representation theory of the *AB*-algebra

The representation theory of the *AB*-algebra is closely related to the representation theory of the underlying Hopf algebra as in the case of the loop algebra. Here we will find precisely one representation which acts in the space of the regular

representation of the Hopf algebra \mathcal{G} .

$$\mathfrak{R} = \bigoplus_I \text{End}(V^I) \quad . \quad (7.2)$$

Here $\text{End}(V^I)$ is regarded as a complex vector space. We will introduce a scalar product on \mathfrak{R} below.

Theorem 21 (Representation π of the AB -algebra) *The AB -algebra \mathcal{T} has one representation π realized on the representation space \mathfrak{R} . In this representation there exists a cyclic vector $|0\rangle$ such that*

$$\pi(B^I)|0\rangle = |0\rangle(\kappa_I)^{-1} \quad (7.3)$$

This property determines the representation π uniquely. π can be extended to a representation of the semi-direct product $\mathcal{T} \times_S \mathcal{G}$ such that the vector $|0\rangle$ is invariant under the action of elements $\xi \in \mathcal{G}$, i.e.

$$\pi(\xi)|0\rangle = |0\rangle\epsilon(\xi) \quad . \quad (7.4)$$

The representation π is faithful on \mathcal{T} , in absence of truncation it is irreducible.

A representation space of \mathcal{T} with properties as specified in the theorem is generated from the “ground state” $|0\rangle$ by application of operators A_{cd}^I . So it is obviously isomorphic to \mathfrak{R} . Moreover, the exchange relations of monodromies B^J and A^I and the transformation properties of A^I together with relations (7.3) determine the action of matrix elements in B^J and of elements $\xi \in \mathcal{G}$ on arbitrary states in \mathfrak{R} .

$$\begin{aligned} \pi(\overset{2}{B}^J)(R')^{IJ} \pi(\overset{1}{A}^I)|0\rangle &= ((R'R)^{-1})^{IJ} (R')^{IJ} \pi(\overset{1}{A}^I)|0\rangle \kappa_J^{-1} \\ \pi(\mu^I(\xi))\pi(A^I)|0\rangle &= \pi(A^I)|0\rangle\epsilon(\xi) \end{aligned}$$

with $\mu^I(\xi) = (\tau^I \otimes id)(\Delta(\xi)) \in \text{End}(V^I) \otimes \mathcal{G}$. The action of A^J can be derived by using functoriality of monodromies A^K

$$\pi(\overset{1}{A}^J)R^{JI} \pi(\overset{2}{A}^I)|0\rangle = \sum C^a[JI|K]^* \pi(A^K)|0\rangle C^a[JI|K] \quad .$$

Faithfulness and irreducibility of π will be demonstrated at the end of the next subsection.

From the structure of π we obtain an important consequence in connection with Theorem 5 in the background review. Let $\mathcal{L}(A) \subset \mathcal{T}$ be the loop algebra generated by matrix elements of A^I . Analogous to eq. (3.37) we define a functional $\omega_A : \mathcal{L}(A) \times_S \mathcal{G} \mapsto \mathbf{C}$ by

$$\omega_A(A^I\xi) = \delta_{I,0}\epsilon(\xi) \quad . \quad (7.5)$$

The positivity result in Theorem 5 furnishes the following proposition.

Proposition 22 (Scalar product for \mathfrak{R}) *Suppose that a_1, a_2 are two elements in \mathfrak{R} and that they are obtained from the ground state $|0\rangle$ by application of $A_1, A_2 \in \mathcal{L}(A)$, i.e. $\pi(A_i)|0\rangle = a_i$ for $i = 1, 2$. Then the formula*

$$\langle a_1, a_2 \rangle \equiv \omega_A((A_1)^* A_2), \quad (7.6)$$

with ω_A given through eq. (7.5), defines a (positive definite) scalar product on \mathfrak{R} , iff all quantum dimensions d_I are positive. With respect to this scalar product, the map $\pi : \mathcal{S}_{1,0} = \mathcal{T} \times_S \mathcal{G} \mapsto \text{End}(\mathfrak{R})$ defined in Theorem 21 is a $*$ -representation.

7.3 Embedding the loop algebra into the AB -algebra

The AB -algebra is closely related to the loop algebra considered above. Obviously, $M^I \mapsto A^I$ as well as $M^I \mapsto B^I$ define embeddings of the loop algebra into AB -algebra. Here we give a more sophisticated embedding which will be of special importance for us. None of the following results has conceptual importance. Nevertheless the subsection serves a twofold purpose: it provides some more background material needed in the proofs of the next section and prepares for Section 9 as well. The calculations done here are typical for the discussion of the mapping class group in our approach.

Lemma 2 (Automorphisms of the AB -algebra) *The maps i, j defined by*

$$\begin{aligned} i(A^I) &= \kappa_I^{-1} B^I A^I & , & & i(B^J) &= B^J & ; \\ j(B^J) &= \kappa_I^{-1} B^I A^I & , & & j(A^J) &= A^J \end{aligned}$$

extend to $*$ -automorphisms of the AB -algebra \mathcal{T} .

PROOF: It suffices to give the proof for i . To begin with, let us determine the multiplication rules of the product $\kappa_I^{-1} B^I A^I$.

$$\begin{aligned} \kappa_I^{-1} \overset{1}{B}^I \overset{1}{A}^I R^{IJ} \kappa_J^{-1} \overset{2}{B}^J \overset{2}{A}^J &= (\kappa_I \kappa_J)^{-1} \overset{1}{B}^I R^{IJ} \overset{2}{B}^J (R')^{IJ} \overset{1}{A}^I R^{IJ} \overset{2}{A}^J \\ &= (\kappa_I \kappa_J)^{-1} \sum C^a[IJ|K]^* B^K C^a[IJ|K] \cdot \\ &\quad \cdot (R')^{IJ} C^b[IJ|L]^* A^L C^b[IJ|L] \\ &= \sum \kappa_K^{-1} C^a[IJ|K]^* B^K A^K C^b[IJ|K] \cdot \end{aligned}$$

This coincides with the multiplication rules for A^I . The exchange relations for $\kappa_I^{-1} B^I A^I$ with B^J are

$$\begin{aligned} \kappa_I^{-1} (R^{-1})^{IJ} \overset{1}{B}^I \overset{1}{A}^I R^{IJ} \overset{2}{B}^J &= \kappa_I^{-1} (R^{-1})^{IJ} \overset{1}{B}^I R^{IJ} \overset{2}{B}^J (R')^{IJ} \overset{1}{A}^I R^{IJ} \\ &= \kappa_I^{-1} \overset{2}{B}^J (R')^{IJ} \overset{1}{B}^I \overset{1}{A}^I R^{IJ} \cdot \end{aligned}$$

In the process of this calculation we inserted a relation of the type (5.2) which follows from the operator products of B^I . Exchange relations for $(\kappa_J)^{-1}B^J A^J$ and A^I are derived in the same way. They coincide with the exchange relations of A^I and B^J . Consistency with the covariance relations is obvious. So it remains to discuss the properties of i with respect to the $*$ -operation.

$$\begin{aligned} i((A^I)^*) &= i(\sigma_\kappa(R^I(A^I)^{-1}(R^{-1})^I)) \\ &= \sigma_\kappa(\kappa_I R^I(A^I)^{-1}(B^I)^{-1}(R^{-1})^I) = (i(A^I))^* . \end{aligned}$$

This proves the lemma.

Now let us come to the main theme of this subsection, namely the embedding of the loop algebra into the AB -algebra.

Lemma 3 *Let elements $(A^I)^{-1}, (B^I)^{-1} \in \text{End}(V^I) \otimes \mathcal{T}$ be defined through the equations $(A^I)^{-1}A^I = e^I = A^I(A^I)^{-1}$ and $(B^I)^{-1}B^I = e^I = B^I(B^I)^{-1}$ as before. Then the map $\hat{\varrho}$,*

$$\hat{\varrho}(M^I) = \kappa_I^3 B^I(A^I)^{-1}(B^I)^{-1}A^I \quad (7.7)$$

extends to an embedding of the loop algebra \mathcal{L} into the AB -algebra \mathcal{T} . The embedding extends to semidirect products with the symmetry algebra \mathcal{G} and respects the action of $$.*

PROOF: We have to determine the multiplication rules for the product on the r.h.s of equation (7.7). In the proof one first inserts the exchange relation for A and B in the middle. Then we can use that $(B^J)^{-1}(A^J)^{-1}$ has the same exchange relations with $A^I [B^I]$ as $(B^J)^{-1} [(A^J)^{-1}]$ (preceding lemma).

$$\begin{aligned} &\kappa_I^3 \overset{1}{B}^I (\overset{1}{A}^I)^{-1} (\overset{1}{B}^I)^{-1} \overset{1}{A}^I R^{IJ} \kappa_J^3 \overset{2}{B}^J (\overset{2}{A}^J)^{-1} (\overset{2}{B}^J)^{-1} \overset{2}{A}^J \\ &= (\kappa_I \kappa_J)^3 \overset{1}{B}^I (\overset{1}{A}^I)^{-1} (\overset{1}{B}^I)^{-1} R^{IJ} \overset{2}{B}^J (R')^{IJ} \overset{1}{A}^I R^{IJ} (\overset{2}{A}^J)^{-1} (\overset{2}{B}^J)^{-1} \overset{2}{A}^J \\ &= (\kappa_I \kappa_J)^3 \overset{1}{B}^I R^{IJ} \overset{2}{B}^J (R^{-1})^{IJ} (\overset{1}{A}^I)^{-1} (\overset{1}{B}^I)^{-1} ((R')^{-1})^{IJ} . \\ &\quad \cdot (\overset{2}{A}^J)^{-1} (\overset{2}{B}^J)^{-1} (R^{-1})^{IJ} \overset{1}{A}^I R^{IJ} \overset{2}{A}^J . \end{aligned}$$

Finally we use the multiplication rules for A^I, B^I and $\kappa_I(A^I)^{-1}(B^I)^{-1}$. With the normalization (3.5) this gives

$$\begin{aligned} &= (\kappa_I \kappa_J)^2 \sum C^a [IJ|K]^* B^K \frac{\kappa_K}{\kappa_I \kappa_J} \kappa_K (A^K)^{-1} (B^K)^{-1} \frac{\kappa_K}{\kappa_I \kappa_J} A^K C^a [IJ|K] \\ &= \sum C^a [IJ|K]^* (\kappa_K)^3 B^K (A^K)^{-1} (B^K)^{-1} A^K C^a [IJ|K] . \end{aligned}$$

To show that $\hat{\varrho} : \mathcal{L} \mapsto \mathcal{T}$ respects the action of $*$ is straightforward. It uses the fact that $((A^I)^{-1})^* = \sigma_\kappa(R^I A^I (R^{-1})^I)$ and $((B^I)^{-1})^* = \sigma_\kappa(R^I B^I (R^{-1})^I)$.

Remark: Let us remark that the embedding given by (7.7) is invariant with respect to automorphisms described in equation (7.7), i.e.

$$i(\hat{\varrho}(M)) = \hat{\varrho}(M) \quad , \quad j(\hat{\varrho}(M)) = \hat{\varrho}(M) \quad (7.8)$$

for all $M \in \mathcal{L}$. The proof is straightforward. Indeed,

$$\begin{aligned} i(\kappa_I^3 B^I (A^I)^{-1} (B^I)^{-1} A^I) &= \kappa_I^3 B^I (\kappa^I (A^I)^{-1} (B^I)^{-1}) (B^I)^{-1} (k_I^{-1} B^I A^I) \\ &= \kappa_I^3 B^I (A^I)^{-1} (B^I)^{-1} A^I \end{aligned}$$

and similarly for j instead of i .

For later application we wish to evaluate the image of $\hat{\varrho}$ in the representation π .

Lemma 4 *The quantum monodromies $\kappa_I^3 B^I (A^I)^{-1} (B^I)^{-1} A^I$ which appear as the image of M^I under the embedding $\hat{\varrho} : \mathcal{L} \mapsto \mathcal{T}$, are represented by*

$$\pi(\kappa_I^3 B^I (A^I)^{-1} (B^I)^{-1} A^I) = \pi(\kappa_I^{-1} (R' R)^I) \quad . \quad (7.9)$$

Here π is regarded as a representation of the semi-direct product $\mathcal{T} \times_S \mathcal{G}$ and $(R' R)^I \equiv (\tau^I \otimes id)(R' R) \in \text{End}(V^I) \otimes \mathcal{G}$.

PROOF: The computation is done in several steps using the eq. (7.3) for π . To begin with, let us show that

$$\pi((B^I)^{-1} A^I |0\rangle) = \pi(A^I |0\rangle) \kappa_I^{-3} \quad .$$

In fact, when a variant of relation (7.1) is applied to the ground state $|0\rangle$ and eq. (7.3) is inserted one obtains

$$\pi((B^J)^{-1} (R^{-1})^{IJ} A^I |0\rangle) = (R')^{IJ} \pi(A^I |0\rangle) \kappa_I \quad . \quad (7.10)$$

Suppose that we expand the inverse of the R -matrix according to $R^{-1} = \sum s_\sigma^1 \otimes s_\sigma^2$. Now multiply the above equation from the left with $\tau^I(\mathcal{S}(s_\sigma^1))$ and from the right by $\tau^J(s_\sigma^2)$ and sum over σ . Then taking the product of the two components (for $I = J$) results in

$$\pi((B^I)^{-1} A^I |0\rangle) = \tau^I(r_\tau^1 \sigma_\sigma^2 \mathcal{S}(s_\sigma^1) r_\tau^2) \pi(A^I |0\rangle) \kappa_I \quad .$$

Finally, a short computation reveals that $r_\tau^1 s_\sigma^2 \mathcal{S}(s_\sigma^1) r_\tau^2 = u^{-1} \mathcal{S}(u^{-1}) = v^{-2} = \kappa^{-4}$. This gives the anticipated formula. As a corollary we note that

$$\pi(\hat{\varrho}(M^I)) |0\rangle = |0\rangle \kappa_I^{-1} \quad .$$

To proceed with the evaluation of $\hat{\varrho}(M^I)$ on more general states, one needs the exchange relation

$$\hat{\varrho}(M^I) R^{IJ} A^J (R^{-1})^{IJ} = (R'^{-1})^{IJ} A^J (R')^{IJ} \hat{\varrho}(M^I) \quad .$$

Its derivation is left as an exercise. From this we may conclude

$$\pi(\hat{\rho}(M^1 R^{IJ} \overset{2}{A}^J)|0) = (R'^{-1})^{IJ} \pi(\overset{2}{A}^J)|0) \kappa_I^{-1}(R'R)^{IJ} .$$

We keep the answer in mind while we notice another formula which can be derived from eq. (7.4) and quasi-triangularity of the R -element.

$$\pi(\kappa_I^{-1}(R'R)^I R^{IJ} \overset{2}{A}^J)|0) = (R'^{-1})^{IJ} \pi(\overset{2}{A}^J)|0) \kappa_I^{-1}(R'R)^{IJ} .$$

At this point we are prepared to finally prove the irreducibility of π in Theorem 21.

PROOF OF IRREDUCIBILITY OF π : We will show directly that the representation π is irreducible. Faithfulness follows from a counting argument. The idea of the proof is this: first we decompose the representation space \mathfrak{R} into certain subspaces and show that a subalgebra of \mathcal{T} acts irreducibly on these subspaces. Then we employ this result to show that every vector in \mathfrak{R} is cyclic. Because of the first part of the proof, it actually suffices to establish cyclicity for one vector in each of the considered subspaces.

To begin with, let us note that the monodromies B^I can be used to project onto subspaces of \mathfrak{R} which are isomorphic to $End(V^J)$. The elements

$$\begin{aligned} \chi_B^J &\equiv \mathcal{N}d_J S_{J\bar{I}} \kappa_{I\bar{r}_q}^I(B^I) \\ \text{satisfy} \quad \pi(\chi_B^J A^I)|0) &= \pi(A^I)|0) \delta_{I,J} . \end{aligned} \quad (7.11)$$

This follows easily with the help of a formula similar to eq. (7.10) and the argument after the proof of Theorem 12. The subspaces $\pi(\chi_B^J)\mathfrak{R}$ carry irreducible representations of a certain subalgebra in \mathcal{T} .

Lemma 5 *The map $v : \mathcal{L}_2 \mapsto \mathcal{T}$ defined by*

$$v(M_1^I) = \kappa_I^2(A^I)^{-1}(B^I)^{-1}A^I \quad , \quad v(M_2^I) = B^I$$

restricts to an embedding of the diagonal subalgebra $\mathcal{L}_2^d \subset \mathcal{L}_2$ into the handle algebra. The image of \mathcal{L}_2^d under v is represented irreducibly on the subspaces $\pi(\chi_B^J)\mathfrak{R} \subset \mathfrak{R}$.

PROOF: It is straightforward to prove that v gives a homomorphism. In order to understand that v furnishes an embedding of \mathcal{L}_2^d into \mathcal{T} it is sufficient study the representations of the image $v(\mathcal{L}_2^d)$.

We infer from

$$\begin{aligned} \pi((\overset{2}{B}^J)^{-1}(R')^{IJ} \overset{1}{A}^I)|0) &= \kappa_I^{-1}(R'R)^{IJ} (R')^{IJ} \pi(\overset{1}{A}^I)|0) \\ \pi\left((\kappa_J^2(\overset{2}{A}^J)^{-1}(\overset{2}{B}^J)^{-1} \overset{2}{A}^J)(R')^{IJ} \overset{1}{A}^I\right)|0) &= (R')^{IJ} \pi(\overset{1}{A}^I)|0) \kappa_J^{-1}(RR')^{IJ} . \end{aligned}$$

that the action of monodromies B^J and $\kappa_B^2(A^J)^{-1}(B^J)^{-1}A^J$ restricts to the subspace $End(V^I)$ on which χ_B^I projects. To gain a better understanding of this action, let us map the spaces $End(V^I) \subset \mathfrak{R}$ to $V^I \otimes V^{\bar{I}}$ by means of

$$w^I \equiv \kappa_I^{-3} C[I\bar{I}|0](R')^{I\bar{I}} a^I R^{I\bar{I}} \in V^I \otimes V^{\bar{I}}$$

for every $a^I \in End(V^I) \subset \mathfrak{R}$. It is easy to check that the monodromies B^J and $(A^J)^{-1}(B^J)^{-1}A^J$ act on w^I according to

$$\begin{aligned} \pi(B^I)w^J &= w^J \kappa_I^{-1} (R'_{12} R'_{13} R_{13} (R'_{12})^{-1})^{IJJ} , \\ \pi((A^I)^{-1}(B^I)^{-1}A^I)w^J &= w^J \kappa_I^{-1} (R'_{12} R_{12})^{IJJ} . \end{aligned}$$

When these formulas are compared with the expressions in Theorem 15 we see that the action B^J and $(A^J)^{-1}(B^J)^{-1}A^J$ on $End(V^I)$ is equivalent to the action of the monodromies $M_1^J, M_2^J \in \mathcal{L}_2$ on the space $V^I \otimes V^{\bar{I}}$. The latter was considered in the previous section and is known to be irreducible by Proposition 15. This proves the lemma.

Now we can go back to discuss the irreducibility of π . We still have to show that every subspace $End(V^I) = \pi(\chi_B^I)\mathfrak{R}$ contains at least one cyclic vector $\Psi^I \in \pi(\chi_B^I)\mathfrak{R}$. Since $|0\rangle$ is cyclic, it suffices to find elements $T^I \in \mathcal{T}$ – one for each vector Ψ^I – with $\pi(T^I)\Psi^I = |0\rangle$. Using the notation $c_A^I = \kappa_I tr_q^I(A^I)$, we choose $\Psi^I \equiv \pi(c_A^I)|0\rangle \in \pi(\chi_B^I)\mathfrak{R}$. The standard relations $c_A^I c_A^J = \sum N_K^{IJ} c_A^K$ furnish

$$\begin{aligned} \pi(T^I)\Psi &= \pi(\chi_B^0 c_A^{\bar{I}} c_A^I)|0\rangle \\ &= \pi(\chi_B^0 \sum N_K^{I\bar{I}} c_A^K)|0\rangle = \pi(c_A^0)|0\rangle = |0\rangle \end{aligned}$$

for $T \equiv \chi_B^0 c_A^{\bar{I}} \in \mathcal{T}$. The calculation employs the fact the c_A^K is constructed from A^K so that eq. (7.11) furnishes $\pi(\chi_B^0 \chi_A^K)|0\rangle = \pi(\chi_A^0)|0\rangle$. This concludes the proof.

8 The Moduli Algebra for Higher Genera

In this section we consider the most general case of the moduli algebra on a Riemann surface of arbitrary genus g with an arbitrary number m of marked points. Our strategy remains similar to preceding sections. We will represent the graph algebra in certain tensor product of representations of the underlying Hopf algebra (cf. all previous sections). Having a set of representations of the graph algebra, we construct the representations of the moduli algebra in the gauge invariant subspaces of the tensor products (cf. Subsection 6.3).

8.1 Representation theory of the graph algebra $\mathcal{L}_{g,m}$

The graph algebra $\mathcal{L}_{g,m}$ was defined in Definition 3. Notice that it consists of m loop algebras (corresponding to the monodromies M_ν^I) and g AB -algebras.

They are pieced together in a rather standard fashion. It will turn out that the discussion of the representation theory is completely parallel to the corresponding arguments in Section 6.2.

So let us begin to construct representations of $\mathcal{L}_{g,m}$. As usual, we will choose some appropriate representation space of the underlying Hopf algebra \mathcal{G} on which we then realize $\mathcal{L}_{g,m}$. Let us introduce the symbol $\mathfrak{S}_g(I_1, \dots, I_m)$ to denote the representation space

$$\mathfrak{S}_g(I_1, \dots, I_m) = V^{I_1} \otimes \dots \otimes V^{I_m} \otimes \mathfrak{R}^{\otimes g} \quad . \quad (8.1)$$

With all the experience we gathered in the preceding subsections we can guess a suitable scalar product for $\mathfrak{S}_g(I_1, \dots, I_m)$ right away. All the $m + g$ factors within the tensor product (8.1) come with a distinguished scalar product. For the carrier spaces V^I of the representations τ^J of the Hopf algebra \mathcal{G} this was part of the input. On \mathfrak{R} we use the scalar product given through eq. (7.6), so that the natural action of \mathcal{G} on \mathfrak{R} becomes a $*$ -representation. In conclusion, the space $\mathfrak{S}_g(I_1, \dots, I_m)$ is a $m + g$ -fold tensor product of Hilbert spaces, each of which carries a $*$ -representation of \mathcal{G} . Now we are in a position to employ the Proposition 16 to construct a scalar product $\langle \cdot, \cdot \rangle$ on $\mathfrak{S}_g(I_1, \dots, I_m)$.

$\mathfrak{S}_g(I_1, \dots, I_m)$ has the best chances to carry a representation of $\mathcal{L}_{g,m}$ because we know already that its first tensor factors $V^{I_1} \otimes \dots \otimes V^{I_m}$ carry a representation of $\mathcal{L}_m \subset \mathcal{L}_{g,m}$. The other part in the tensor product (8.1) is a g -fold tensor power of the regular representation. Each copy of \mathfrak{R} can carry a representation of AB -algebra (Theorem 21). In fact, if \mathcal{L}_m and the g copies of the AB -algebra would come into $\mathcal{L}_{g,m}$ in the form of a Cartesian product, the construction of the representation would have been obvious. Even though this is not the case, we can use our previous experience to define representations $\Lambda_g(I_1, \dots, I_n)$ of the graph algebra $\mathcal{L}_{g,m}$ on the spaces $\mathfrak{S}_g(I_1, \dots, I_n)$. Let us introduce the notation π_i for the representation π of the i^{th} copy $\mathcal{T}_i \subset \mathcal{L}_{g,m}$ of the AB -algebra implemented in the i^{th} copy of \mathfrak{R} in the tensor product (8.1), i.e. for every $T \in \mathcal{T}_i$,

$$\pi_i(T) = id_{I_1} \otimes \dots \otimes id_{\mathfrak{R}_{i-1}} \otimes \pi(T) \otimes id_{\mathfrak{R}_{i+1}} \otimes \dots \otimes id_{\mathfrak{R}_g} \quad . \quad (8.2)$$

Another useful object is the following representation of the Hopf algebra \mathcal{G} .

$$\begin{aligned} j_1 &= \epsilon \quad \text{and} \\ j_i(\xi) &= (\tau^{I_1} \boxtimes \dots \boxtimes \pi_{i-1})(\xi) \otimes id_{\mathfrak{R}_i} \otimes \dots \otimes id_{\mathfrak{R}_g} \quad (i \geq 2) \end{aligned}$$

Here \boxtimes denotes the tensor product of representations defined through the co-product in the standard way. The representation $j = j_{g+1}$ coincides with the natural action of \mathcal{G} in the space $\mathfrak{S}_g(I_1, \dots, I_m)$. Now we are ready to formulate a theorem.

Theorem 23 (Representations of the algebra $\mathcal{L}_{g,m}$) *A representation $\Lambda_g^{I_1, \dots, I_m}$ of $\mathcal{L}_{g,m}$ acts in the space $\mathfrak{S}_g(I_1, \dots, I_m)$ by means of the following set of equations.*

$$\Lambda_g^{I_1, \dots, I_m}(M_\nu^J) = D^{I_1, \dots, I_m}(M_\nu^J) \otimes id_{\mathfrak{R}}^{\otimes g} \quad ,$$

$$\begin{aligned}\Lambda_g^{I_1, \dots, I_m}(A_i^J) &= (\tau^J \otimes j_i)(R')\pi_i(A_i^J)(\tau^J \otimes j_i)((R')^{-1}) \ , \\ \Lambda_g^{I_1, \dots, I_m}(B_i^J) &= (\tau^J \otimes j_i)(R')\pi_i(B_i^J)(\tau^J \otimes j_i)((R')^{-1}) \ .\end{aligned}$$

$\Lambda_g^{I_1, \dots, I_m}$ extends to a representation of the semi-direct product $\mathcal{S}_{g,m} = \mathcal{L}_{g,m} \times_S \mathcal{G}$ by means of

$$\Lambda_g^{I_1, \dots, I_m}(\xi) = j(\xi) \ .$$

When $\mathfrak{S}_g(I_1, \dots, I_m)$ is equipped with the scalar product $\langle \cdot, \cdot \rangle$ as discussed after eq. (8.1), the map $\Lambda_g^{I_1, \dots, I_m} : \mathcal{S}_{g,m} \mapsto \text{End}(\mathfrak{S}_g(I_1, \dots, I_m))$ is a $*$ -representation. The set of representations $\{\Lambda_g^{\{I_\nu\}}\}$ is faithful on $\mathcal{L}_{g,m}$. In absence of truncation this implies that the every representation $\Lambda_g^{\{I_\nu\}}$ is irreducible.

PROOF: On the basis of our prior work, there is nothing left to be discussed here. With the relations (3.16) through (3.20) being of the same type as our well known eq. (3.15), the proof is straightforward (i.e. essentially identical to the proof of Theorem 15).

8.2 The moduli algebra $\mathcal{M}_g^{\{K_\nu\}}$

Having the set of representations $\Lambda_g^{I_1, \dots, I_m}$ of $\mathcal{L}_{g,m}$ at hand we can proceed as in Subsection 6.3. So we notice that the space $\mathfrak{S}_g(I_1, \dots, I_m)$ carries a representation of the gauge invariant subalgebra $\mathcal{A}_{g,m}$ within $\mathcal{L}_{g,m}$. Under the action of $\mathcal{A}_{g,m}$ the space $\mathfrak{S}_g(I_1, \dots, I_m)$ splits into a sum of irreducible representations. As is the case of \mathcal{L}_m , this decomposition reads

$$\mathfrak{S}_g(I_1, \dots, I_m) = \sum_J V^J \otimes W_g^J(I_1, \dots, I_m) \ , \quad (8.3)$$

where J runs through all equivalence classes of irreducible representations of \mathcal{G} and $W_g^J(I_1, \dots, I_m)$ are multiplicity spaces. We note that the scalar product $\langle \cdot, \cdot \rangle$ on $\mathfrak{S}_g(I_1, \dots, I_m)$ restricts to $W_g^J(I_1, \dots, I_m)$ and that these spaces carry an irreducible $*$ -representation of $\mathcal{A}_{g,m}$. These representations can be used to obtain representations of the moduli algebra which we discuss next.

Recall that we have m marked points on the Riemann surface. They are labeled by K_1, \dots, K_m . Each of these points is surrounded by one of the loops l_ν . To implement the corresponding flatness relations in the finite dimensional case, we use the characteristic projectors $\chi_\nu^{K_\nu}$ which are constructed from monodromies M_ν^I . From the arguments in Section 6.1 one concludes that these projectors are central in $\mathcal{A}_{g,m} \subset \mathcal{L}_{g,m}$. Still we need one more projector that comes with the total product $r_g = [b_g, a_g^{-1}] \dots [b_1, a_1^{-1}] l_m \dots l_1$. As in section 3.5 we define

$$\chi_0^K \equiv \mathcal{N} d_K S_{KI} c_0^I = \mathcal{N} d_K \kappa_K S_{KI} \text{tr}_q^I(M^I(r_g)) \quad (8.4)$$

$$\text{with} \quad M^I(r_g) = \kappa_I^{4g+m-1} [B_g^I, (A_g^I)^{-1}] \dots M_1^I \ .$$

Here $[B_i^I, (A_i^I)^{-1}] = B_i^I (A_i^I)^{-1} (B_i^I)^{-1} A_i^I$. The elements χ_0^K generate a fusion algebra and are *central* in \mathcal{A}_m (see [3]).

Definition 24 (Moduli algebra for arbitrary surface) *The moduli algebra $\mathcal{M}_{g,m}^{\{K_\nu\}}$ of a surface of genus g with m punctures marked by $K_\nu, \nu = 1, \dots, m$, is the $*$ -algebra*

$$\mathcal{M}_{g,m}^{\{K_\nu\}} \equiv \chi_0^0 \prod_{\nu=1}^m \chi_\nu^{K_\nu} \mathcal{A}_{g,m} \quad . \quad (8.5)$$

Here $\chi_\nu^{K_\nu}, \chi_0^0 \in \mathcal{A}_{g,m}$ are the central projectors introduced in the text preceding this definition.

Along the lines of the corresponding discussion in Section 6.3, we can evaluate the projectors $\chi^K \in \mathcal{A}_{g,m}$ on the representation spaces $W_g^J(I_1, \dots, I_m)$. For the character χ_0^0 one uses the fact that the product $\tilde{M}_i^I = \kappa_I^3 B_i^I (A_i^I)^{-1} (B_i^I)^{-1} A_i^I$ which is assigned to $[b_i, a_i^{-1}]$, embeds the loop algebra so that the element assigned to r_g looks as if it would come from $m + g$ loops. Because of eq. (7.9), this holds also for the way the elements are represented on $\mathfrak{S}_g(I_1, \dots, I_m)$. Consequently, the evaluation of characters on multiplicity spaces is identical to the calculation we did in the Section 6.3 and we can state the results right away.

Theorem 25 (Representations of the moduli algebra, genus g) *For any set K_1, \dots, K_m labeling m points on a Riemann surface of genus g , there is a unique irreducible $*$ -representation of the corresponding moduli algebra $\mathcal{M}_{g,m}^{\{K_\nu\}}$ on the space $W_g^0(K_1, \dots, K_m)$ (defined through the decomposition (8.3)). This representation can be obtained explicitly by restricting the representation $\Lambda_g^{K_1, \dots, K_m}$ of $\mathcal{L}_{g,m}$ to the moduli algebra $\mathcal{M}_{g,m}^{\{K_\nu\}} \subset \mathcal{L}_{g,m}$.*

8.3 The second pinching theorem

We would like to extend our description of relations between moduli algebras that was initiated in Section 6.4. It is obvious how Proposition 20 carries over to the moduli algebras on higher genus surfaces. But now we have another possibility: we can also shrink the surface along a circle that wraps around some handle. To be specific, we chose the fusion algebra $\mathcal{V}(b_1)$ constructed from the elements B_1^I and evaluate its commutant. Recall that $\mathcal{V}(b_1)$ is generated by

$$c^I = \kappa_I \text{tr}_q^I(B_1^I) \quad .$$

Proposition 26 (Second Pinching Theorem) *The commutant of $\mathcal{V}(b_1)$ in the moduli algebra $\mathcal{M}_{g,m}^{K_1, \dots, K_m}$ splits into the direct sum of moduli algebras of genus $g - 1$ with $m + 2$ marked points,*

$$\mathcal{C}(\mathcal{V}(b_1), \mathcal{M}_{g,m}^{K_1, \dots, K_m}) \cong \bigoplus_K \mathcal{M}_{g-1, m+2}^{K_1, \dots, K_m, K, \bar{K}} \quad . \quad (8.6)$$

Here the sum runs over all classes of irreducible representations of the symmetry Hopf algebra.

In the language of Topological Field Theory, evaluation of the commutant corresponds to shrinking the cycle b_1 so that we get a surface of lower genus. It has two marked points at the place where the handle is pinched – one on either side of the cut. Shrinking all the b -cycles one after another, one produces spheres with $m + 2g$ marked points.

PROOF: To prove the theorem we proceed as in Section 6.4. Let us first show how to embed the direct sum on the right hand side of (8.6) into the moduli algebra. The set of matrix generators M_ν^I ($\nu = 1, \dots, m$), $\kappa_I^2 B_1^I (A_1^I)^{-1} (B_1^I)^{-1}$, A_1^I and A_i^I, B_i^I ($i = 2, \dots, g$) can be regarded as an image of the standard generators of $\mathcal{L}_{g-1, m+2}$ under a map $\phi : \mathcal{L}_{g-1, m+2} \mapsto \mathcal{L}_{g, m}$. ϕ is not an embedding. But the proof for Theorem 21 at the end of Subsection 7.3 shows that ϕ restricts to an embedding of the direct sum $\bigoplus_K \mathcal{M}_{g-1, m+2}^{\{K_1, \dots, K_m, K, \bar{K}\}}$ into the moduli algebra $\mathcal{M}_{g, m}^{\{K_1, \dots, K_m\}}$ (cp. also Lemma 5). Counting dimensions we find that every summand is embedded with multiplicity one so that the commutant of the image of ϕ is exactly the fusion algebra. For details the reader is referred to the proof of the Proposition 20.

9 Representations of Mapping Class Groups

The action of the mapping class group $M(g, m)$ on the fundamental group of a surface $\Sigma_{g, m}$ of genus g with m punctures induces an action on the graph algebras $\mathcal{L}_{g, m}$, i.e. a homomorphism from $M(g, m)$ into the automorphism group of $\mathcal{L}_{g, m}$. In general, only automorphisms corresponding to the pure mapping class group $PM(g, m) \subset M(g, m)$ restrict to automorphisms of the moduli algebras $\mathcal{M}_{g, m}^{\{K_\nu\}}$. Since the moduli algebras are simple, every automorphism is inner and can be implemented by a unitary element. We will give a simple prescription to construct such unitaries for a generating set of elements in $PM(g, m)$. They will furnish projective representations of $PM(g, m)$. The latter are equivalent to those found by Reshetikhin and Turaev [37] (extended to the possible presence of punctures)¹.

9.1 Action of the mapping class group on moduli algebras

To begin with, let us recall that the quantum monodromies $M_\nu^I, A_i^I, B_i^I \in \mathcal{L}_{g, m}$ are assigned to the generators $l_\nu, a_i, b_i \in \pi_1(\Sigma_{g, m} \setminus D)$ ². We want to display this

¹As we discussed in [2, 3], our theory generalizes to quasi-Hopf algebras. So the discussion of mapping class groups covers the extension of the Reshetikhin-Turaev construction found by Altschuler and Coste [6].

²If we remove a disk D from the surface, the fundamental group is freely generated by l_ν, a_i, b_i . We will later glue the disk back and thereby introduce the relation 2.6

more clearly in the notations and hence introduce

$$M^I(l_\nu) \equiv M_\nu^I \quad , \quad M^I(a_i) \equiv A_i^I \quad , \quad M^I(b_i) \equiv B_i^I \quad .$$

We can go even further and define $M^I(\mathcal{C})$ for arbitrary elements $\mathcal{C} \in \pi_1(\Sigma_{g,m} \setminus D)$. Suppose that $\mathcal{C} = \mathcal{C}_1\mathcal{C}_2$ with two elements $\mathcal{C}_i, i = 1, 2$, in the fundamental group of $\Sigma_{g,m}$. Then we set

$$M^I(\mathcal{C}) \equiv \kappa_I^{w(\mathcal{C}_1, \mathcal{C}_2)} M^I(\mathcal{C}_1) M^I(\mathcal{C}_2) \quad . \quad (9.1)$$

Here $w(\mathcal{C}_1, \mathcal{C}_2) = \pm 1$ is determined from the pair $(\mathcal{C}_1, \mathcal{C}_2)$ as follows. Suppose that we have presentations of \mathcal{C}_1 and \mathcal{C}_2 in terms of generators $l_\nu^\pm, a_i^\pm, b_i^\pm$. We assume that these presentations are reduced so that neighboring elements are never inverse to each other. From these presentations we extract two generators $c_i \in \{l_\nu^\pm, a_i^\pm, b_i^\pm\}$ such that $\mathcal{C}_1 = c_1' c_1$ and $\mathcal{C}_2 = c_2 c_2'$. Without restriction we can assume that $c_1 \neq c_2^{-1}$. The weight w that we want to describe satisfies $w(\mathcal{C}_1, \mathcal{C}_2) = w(c_1, c_2)$. To define the latter we need to introduce two maps t, s from the set of generators $\{l_\nu^\pm, a_i^\pm, b_i^\pm\}$ to the integers $1, \dots, 2m + 4g$.

$$\begin{aligned} t(l_\nu) &= 2\nu = s(l_\nu) + 1 & , & & t(a_i) &= 2m + 4i = s(a_i) + 2 & , \\ t(b_i) &= 2m + 4i - 1 & = & s(b_i) + 2 \end{aligned}$$

and $t(c^-) = s(c)$ for every $c \in \{l_\nu^\pm, a_i^\pm, b_i^\pm\}$. Now we can complete the description of the weight w .

$$w(c_1, c_2) \equiv \begin{cases} +1 & \text{if } t(c_1) < s(c_2) \\ -1 & \text{if } t(c_1) > s(c_2) \end{cases} \quad (9.2)$$

for all $c_1, c_2 \in \{l_\nu^\pm, a_i^\pm, b_i^\pm\}$. Our choice of the weight factor in the definition (9.1) is designed such that all monodromies $M^I(\mathcal{C})$ satisfy functoriality. We have seen particular examples of this in subsection 7.3.

The mapping class group $M(g, m)$ of a surface $\Sigma_{g,m}$ is defined as the group of diffeomorphisms of $\Sigma_{g,m}$ into itself modulo its identity component. Similarly, $M(g, m; B)$ is obtained from diffeomorphisms of $\Sigma_{g,m} \setminus D$ which leave the boundary $B = \partial D$ pointwise fixed. Elements in $M(g, m)$ and $M(g, m; B)$ may interchange the punctures. This furnishes the usual canonical homomorphism from mapping class groups into the symmetric group. The kernel of this homomorphism is called pure mapping class group. We will denote it by $PM(g, m)$ and $PM(g, m; B)$.

It is well known that elements ϱ in the mapping class group $M(g, m; B)$ of the m -punctured surface act on the fundamental group $\pi_1(\Sigma_{g,m} \setminus D)$ as outer automorphisms. We will not distinguish in notation between elements ϱ in $M(g, m; B)$ and the corresponding elements $\varrho \in \text{Aut}(\pi_1(\Sigma_{g,m} \setminus D))$. The action of the mapping class group on the fundamental group lifts to an action on the graph algebras by means of the formula

$$\hat{\varrho}(M^I(\mathcal{C})) = M^I(\varrho(\mathcal{C})) \quad \text{for all } \mathcal{C} \in \pi_1(\Sigma_{g,m} \setminus D) \quad .$$

Ultimately, we are more interested in automorphisms of moduli algebras. As a first step in the reduction from the graph algebra $\mathcal{L}_{g,m}$ to the moduli algebras, one notices that the automorphisms $\hat{\varrho}$ are consistent with the transformation law under the action of $\xi \in \mathcal{G}$. Consequently, the action of $\hat{\varrho}$ on $\mathcal{L}_{g,m}$ descends to an action on $\mathcal{A}_{g,m}$ (for notations compare Section 8). To proceed towards the moduli algebra, two more steps are necessary. First we have to multiply $\mathcal{A}_{g,m}$ by the projectors $\chi_\nu^{K_\nu}$, then we need to implement flatness for the circle $r_g = [b_g, a_g^{-1}] \dots l_1$ with the help of χ_0^0 . It is intuitively clear that only automorphisms assigned to elements in the pure mapping class group $PM(g, m; B)$ survive the first step which corresponds to coloring the punctures. To understand the effect of χ_0^0 , we recall the relation (a proof can be found in [3])

$$\chi_0^0 M^L(r_g) = \chi_0^0 \kappa_L^{-1} e^L \quad . \quad (9.3)$$

It implements the defining relation $r_g = id$ for $\pi_1(\Sigma_{g,m})$ into the moduli algebra. One may check that all the automorphisms constructed from elements in the (pure) mapping class group respect this relation (i.e. χ_0^0 is invariant under their action). On the other hand, some of the elements in $PM(g, m; B)$ act trivially on the moduli algebras because $M^L(r_g) \sim \kappa_L^{-1} e^L$. A more detailed investigation shows that nontrivial automorphisms correspond to elements in $PM(g, m)$. We formulate this as a proposition.

Proposition 27 (Action of mapping class group) *For every $\varrho \in M(g, m; B)$ there exists an automorphism $\hat{\varrho} : \mathcal{L}_{g,m} \mapsto \mathcal{L}_{g,m}$ of graph algebras,*

$$\hat{\varrho}(M^I(\mathcal{C})) = M^I(\varrho(\mathcal{C})) \quad \text{for all } \mathcal{C} \in \pi_1(\Sigma_{g,m} \setminus D) \quad .$$

These automorphisms furnish an action of the mapping class group $M(g, m; B)$ on the graph algebra $\mathcal{L}_{g,m}$. Automorphisms $\hat{\eta}$ corresponding to elements $\eta \in PM(g, m; B)$ restrict to the moduli algebras $\mathcal{M}_{g,m}^{\{K_\nu\}}$ and give rise to an action of the pure mapping class group $PM(g, m)$ on moduli algebras.

The proof of this proposition is technically not very difficult. Given an explicit description of the action of $M(g, m; B)$ on the fundamental group, it is essentially based on calculations similar to those performed in Section 7.3. Guided by the explanations above, the reader may try to verify the result. A complete proof will also appear in [4].

9.2 Projective representations of mapping class groups

In Proposition 27 we obtained an action of the pure mapping class group on moduli algebras. Let us recall that the moduli algebras $\mathcal{M}_{g,m}^{\{K_\nu\}}$ are simple so that all automorphisms are inner. This means that for every element η in the pure mapping class group there is a unitary element $\hat{h}(\eta)$ in the moduli algebra so that

$$\hat{h}(\eta) A = \hat{\eta}(A) \hat{h}(\eta) \quad .$$

Such elements \hat{h} provide a projective representation of the pure mapping class group. In fact, let $\eta_i, i = 1, 2$, be two elements in $PM(g, m)$ and denote corresponding elements in the moduli algebra by $\hat{h}_i = \hat{h}(\eta_i)$. Suppose that the product $\hat{\eta} = \hat{\eta}_1 \hat{\eta}_2$ is implemented by \hat{h} . Then

$$\hat{h}^* \hat{h}_1 \hat{h}_2 A = A \hat{h}^* \hat{h}_1 \hat{h}_2$$

for all elements $A \in \mathcal{M}_{g,m}^{\{K\nu\}}$. Since the moduli algebra is simple, only scalars can commute with all elements and hence $\hat{h}_1 \hat{h}_2 = \varpi \hat{h}$ with a complex number ϖ .

In constructing this representation, the only problem is to find explicit expressions for the elements \hat{h} , at least for a generating set of elements $\eta \in PM(g, m)$. This is surprisingly simple. Suppose that η is a Dehn twist along the circle $x(\eta)$. Let us regard $x(\eta)$ as an element in the fundamental group so that $M^I(x(\eta))$ is well defined. Then we set

$$\hat{h}(\eta) \equiv \sum \theta^{-1} \mathcal{N} d_I v_I \kappa_I tr_q^I(M^I(x(\eta))) \quad (9.4)$$

$$\text{where} \quad \theta = \sum \mathcal{N} v_I d_I^2 \quad (9.5)$$

and $\mathcal{N} = (\sum d_I^2)^{-1/2}$. We wish to demonstrate that $\hat{h}(x)$ is unitary. Setting $c_x^L \equiv \kappa_L tr_q^L(M^L(x))$ we obtain

$$\begin{aligned} \theta \theta^* \hat{h}(x) \hat{h}(x)^* &= \sum \frac{v_I}{v_J} d_I d_J \mathcal{N}^2 c_x^I c_x^J \\ &= \sum \frac{v_I}{v_J} d_I d_J \mathcal{N}^2 N_K^{IJ} c_x^K \\ &= \sum \mathcal{N} \frac{1}{v_K} d_I S_{I\bar{K}} c_x^K \\ &= \sum S_{0I} S_{I\bar{K}} \frac{1}{v_K} c_x^K \\ &= \sum C_{0\bar{K}} \frac{1}{v_K} c_x^K = 1 \end{aligned}$$

Here we made use of the following expression for the matrix S

$$S_{I\bar{K}} = \mathcal{N} \frac{v_I v_K}{v_J} N_{\bar{J}}^{I\bar{K}} d_{\bar{J}} \ .$$

Now we recall that $\vartheta(c_x^I) = d_I$ defines a representations ϑ of the fusion algebra $\mathcal{V}(x)$ over the circle x . The definition (9.4) shows that in particular $\vartheta(\hat{h}(x)) = 1$. If we apply ϑ to the equality $1 = \theta \theta^* \hat{h}(x) \hat{h}(x)^*$, we see that $1 = \vartheta(\theta \theta^* \hat{h}(x) \hat{h}(x)^*) = \theta \theta^*$. This means that θ is a phase and hence

$$\hat{h}(x) \hat{h}(x)^* = \theta^* \theta = 1 \quad (9.6)$$

Notice that $\hat{h}(x)$ is an element in the fusion algebra $\mathcal{V}(x)$ over x . In particular it can be expressed as a linear combination of the characters $\chi^I(x)$. The outcome of a short calculation using the same ideas as the above proof for the unitarity of $\hat{h}(x)$ is

$$\hat{h}(x) = \sum v_I^{-1} \chi^I(x) \quad . \quad (9.7)$$

Our result (9.7) shows that $\hat{h}(x)$ is simply the *inverse of the ribbon element $v(x)$ over the circle x* .

Theorem 28 (Representation of $PM(g, m)$) *Suppose that $\eta \in PM(g, m)$ is a Dehn twist along the circle $x(\eta)$ on the surface $\Sigma_{g, m}$. Then the unitary element $\hat{h}(x(\eta))$ defined through eq. (9.4) implements the action of $\eta \in PM(g, m)$ on the moduli algebras, i.e.*

$$\hat{h}(x(\eta))A = \hat{\eta}(A)\hat{h}(x(\eta))$$

holds for all elements A in the moduli algebras. The map $\eta \mapsto \hat{h}(x(\eta))$ defines a unitary projective representation of the pure mapping class group $PM(g, m)$ (recall that Dehn twists η generate $PM(g, m)$).

In spite of its appearance, the preceding Theorem is relatively cumbersome to prove because a lot of cases have to be investigated separately. To keep this work compact, we will give the proof elsewhere [4].

9.3 Equivalence with Reshetikhin Turaev representation

We turn now to a more explicit description of the projective representation which we have just constructed. The plan is to evaluate the action of $\hat{h}(x(\eta))$ on the states of the CS -theory. This will then allow to compare our representation with the action of mapping class groups on conformal blocks and the Reshetikhin-Turaev representation.

Let us begin by stating the main theorem of this section.

Theorem 29 (Equivalence with RT-representation) *The projective representation $\eta \mapsto \hat{h}(x(\eta)) \in \mathcal{A}_{g, m}$ of the pure mapping class group $PM(g, m)$ is unitarily equivalent the representation found by Reshetikhin and Turaev in [37].*

The rest of the section is devoted to the proof of this theorem. For this comparison of our representation with the Reshetikhin-Turaev representation it suffices to evaluate the elements $\hat{h}(x(\eta))$ for a generating set of Dehn twists. We use a set which consists of Dehn twists $\eta_{\nu p}, 1 \leq \nu \leq m, \nu < p \leq m + 2g$ and $\alpha_i, \beta_i, \delta_i, \epsilon_i, i = 1, \dots, g$, along the circles $x(\eta_{\nu p})$ and $x(\alpha_i), x(\beta_i), x(\delta_i), x(\epsilon_i)$. More precisely we define

$$\begin{aligned} x(\eta_{\nu p}) &= l_p l_\nu \quad , \quad x(\alpha_1) = l_{m+1} \quad , \\ \text{and } x(\alpha_j) &= l_{m+2j-1} l_{m+2j-2} \quad \text{for } j = 2, \dots, g \quad , \end{aligned}$$

$$x(\beta_i) = a_i \quad , \quad x(\delta_i) = l_{2i-1} \quad ,$$

$$x(\epsilon_i) = l_{m+2i-1} \dots l_{m+1} \quad \text{for } i = 1, \dots, g \quad .$$

where $l_\nu, \nu = 1, \dots, m$ and $a_i, i = 1, \dots, g$, are defined as before and we introduced $l_p, m < p < m + 2g$ by

$$l_{m+2i-1} \equiv a_i^{-1} b_i^{-1} a_i \quad , \quad l_{m+2i} \equiv b_i$$

for $i = 1, \dots, g$. The circles are shown in the Figure 1,2 .

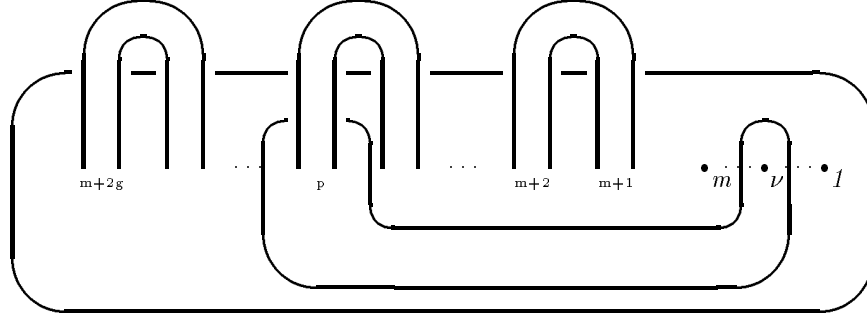

Fig. 1: Curves $x(\eta_{\nu p}), 1 \leq \nu \leq m, \nu < p \leq m + 2g$ on a surface $\Sigma_{g,m}$ with m marked points wrap around the ν^{th} puncture and the p^{th} “leg” if $m < p \leq m + 2g$. If $p \leq m$, $x(\eta_{\nu p})$ encloses the ν^{th} and the p^{th} puncture.

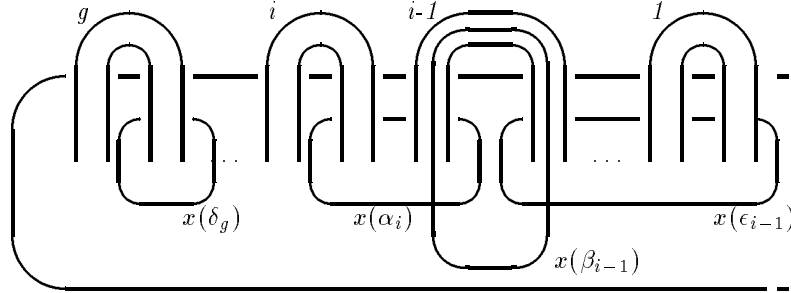

Fig. 2: Curves $x(\alpha_i), x(\beta_i), x(\delta_i), x(\epsilon_i), i = 1, \dots, g$, on a surface $\Sigma_{g,m}$ along which the Dehn twists $\alpha_i, \beta_i, \delta_i, \epsilon_i$ are performed. If there are punctures on the surface, they are not encircled by the curves.

As in Lemma 5 we can map the representation spaces $\mathfrak{S}(K_1, \dots, K_m) \otimes \mathfrak{R}^{\otimes g}$ to $\bigoplus_{\{J_i\}} \mathfrak{S}(K_1, \dots, K_m) \otimes V^{J_1} \otimes V^{\bar{J}_1} \otimes \dots \otimes V^{J_g} \otimes V^{\bar{J}_g}$. This space carries a representation $D_g^{K_1, \dots, K_m}$ of the graph algebra $\mathcal{L}_{g,m}$. The representation $D_g^{K_1, \dots, K_m}$ is unitarily equivalent to $\Lambda_g^{K_1, \dots, K_m}$.

Now we evaluate the basic generators of the pure mapping class group in the representations $D_g^{K_1, \dots, K_m}$.

Lemma 6 *In the representations $D_g^{\{K_\nu\}}$ on $\bigoplus_{\{J_i\}} \mathfrak{S}(K_1, \dots, K_m) \otimes V^{J_1} \otimes V^{\bar{J}_1} \otimes \dots \otimes V^{J_g} \otimes V^{\bar{J}_g}$ the elements $\hat{h}_{\nu p} \in \mathcal{L}_{g,m}, 1 \leq \nu \leq m, \nu < p \leq m + 2g$, are represented by*

$$D_g^{\{K_\rho\}}(\hat{h}_{\nu p}) = \bigoplus_{\{J_i\}} (v_\nu^{-1} v_p^{-1} Q_{\nu p})^{K_1 \dots K_m J_1 \bar{J}_1 \dots J_g \bar{J}_g}$$

and elements $\hat{a}_i, \hat{b}_i, \hat{d}_i, \hat{e}_i, i = 1, \dots, g$, are represented by

$$D_g^{\{K_\rho\}}(\hat{a}_i) = \bigoplus_{\{J_j\}} (v_{m+2i-2}^{-1} v_{m+2i-1}^{-1} Q_{(m+2i-2)(m+2i-1)})^{K_1 \dots K_m J_1 \bar{J}_1 \dots J_g \bar{J}_g} ,$$

$$D_g^{\{K_\rho\}}(\hat{b}_i) = \theta^{-1} \bigoplus_{\{J_j\}} \sum_K \mathcal{N} d_{K v_K v_{\bar{J}_i}} C[J_i \bar{J}_i | 0] (R')^{J_i K} (R')^{K \bar{J}_i} C[K \bar{K} | 0]^c ,$$

$$D_g^{\{K_\rho\}}(\hat{d}_i) = \bigoplus_{\{J_j\}} (v_{m+2i-1})^{K_1 \dots K_m J_1 \bar{J}_1 \dots J_g \bar{J}_g} ,$$

$$D_g^{\{K_\rho\}}(\hat{e}_i) = \bigoplus_{\{J_j\}} (v_{m+1}^{-1} \dots v_{m+2i-1}^{-1} Q_{(m+1)(m+2i-1)} \cdot Q_{(m+2i-2)(m+2i-1)})^{K_1 \dots J_g} .$$

Here $\hat{h}_{\nu p} = \hat{h}(x(\eta_{\nu p}))$, $\hat{a}_i = \hat{h}(x(\alpha_i))$, etc. To simplify the expressions we also used the element $Q_{\nu \mu} \in \mathcal{G}^{\otimes m+2g}$,

$$Q_{\nu \mu} = R'_{\nu(\nu+1)} \dots R'_{\nu \mu} R_{\nu \mu} (R'_{\nu(\mu-1)})^{-1} \dots (R'_{\nu(\nu+1)})^{-1} \in \mathcal{G}^{\otimes m} .$$

$$\text{and} \quad C[K \bar{K} | 0]^c \equiv (R')^{K \bar{K}} C[K \bar{K} | 0]^* \frac{d_K}{v_K} .$$

Fig. 3,4 give a graphical presentation of the result.

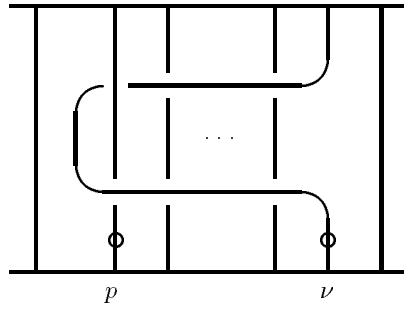

Fig. 3: Pictorial presentation of Lemma 6. The picture contains $m + 2g$ strands, one for every puncture and two for every handle. It shows the action of $\eta_{\nu p}, 1 \leq \nu \leq m, \nu < p \leq m + 2g$ on states. Over- and undercrossings correspond to factors R, R^{-1} and the open circle on a line s means multiplication with $v_{K_s}^{-1}$.

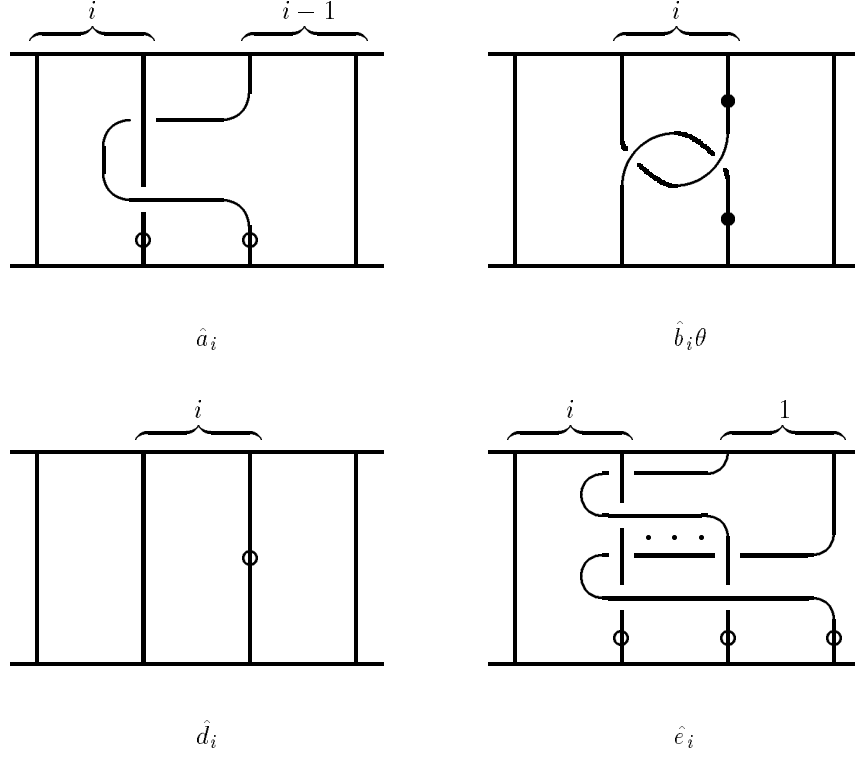

Fig. 4: Pictorial presentation of the action of $\hat{a}_i, \dots, \hat{e}_i$ on states. Pairs of strands correspond to the g handles of the surface and describe a map on \mathfrak{R} . As usual, over- and undercrossings have to be interpreted as factors R, R^{-1} and open (closed) circles in a line stay for a factor v^{-1} (v). Maxima and minima mean insertion of normalized Clebsch-Gordan maps $C[\bar{I}I|0]$ and their conjugates.

PROOF OF THE LEMMA: The simplest case is the action of $\hat{\eta}_{\nu p}$ for $p \leq m$. For notational reasons we give the proof only in the example $\nu = 1, p = 3$. The general case can be treated with the same ideas. With the definition (9.4) of \hat{h}_{13} and the formulas in Theorem (15) for the representation on monodromies M_1^I and M_3^I one finds

$$\begin{aligned}
& D^{\{K_\rho\}}(\hat{h}_{13}) \\
&= \sum \mathcal{N}\theta^{-1} d_I v_I \text{tr}_q^I [(R'_{12} R'_{13} R'_{14} R_{14} (R'_{13})^{-1} R_{12})^{IK_1 K_2 K_3}] \\
&= \sum \mathcal{N}\theta^{-1} d_I v_I \text{tr}_q^I [(R'_{12} R_{34}^{-1} R'_{14} R_{14} R_{34} R_{12})^{IK_1 K_2 K_3}] \\
&= \sum \mathcal{N}\theta^{-1} d_I v_I \text{tr}_q^I [(R_{34}^{-1} [(id \otimes id \otimes \Delta)(R'_{13} R_{13})]_{1324} R_{34})^{IK_1 K_2 K_3}] \quad .
\end{aligned}$$

For the equalities we used quasitriangularity of R several times and the subscript 1324 means that the second and third component of the expression in brackets are exchanged. Now let us recall that $\sum \mathcal{N} \theta^{-1} d_I v_I tr_q^I((R'R)^I) = v^{-1}$ so that

$$\begin{aligned} D^{\{K_\rho\}}(\hat{h}_{13}) &= [(R_{34}^{-1}[(id \otimes id \otimes \Delta)(e \otimes e \otimes v^{-1})]_{1324} R_{34})^{IK_1 K_2 K_3}] \\ &= v_{K_1}^{-1} v_{K_3}^{-1} (R_{34}^{-1} R'_{24} R_{24} R_{34})^{IK_1 K_2 K_3} \\ &= v_{K_1}^{-1} v_{K_3}^{-1} (R'_{23} R'_{24} R_{24} (R'_{23})^{-1})^{IK_1 K_2 K_3} \quad . \end{aligned}$$

We inserted the formula (3.3) for the action of Δ on the ribbon element v and employed the Yang Baxter equation. The last formula coincides with the statement in the Lemma.

To compute the action of the $\hat{h}_{\nu p}, p > m$, on states we use a map from the representation space \mathfrak{R} of the AB - algebra \mathcal{T} to the space $\bigoplus_J V^J \otimes V^{\bar{J}}$ described by

$$w^J \equiv \kappa_J^{-3} C[J\bar{J}|0](R')^{J\bar{J}} a^J R^{J\bar{J}} \in V^J \otimes V^{\bar{J}} \quad (9.8)$$

for every $a^J \in End(V^J) \subset \mathfrak{R}$. It is easy to check that the monodromies B^I and $(A^I)^{-1}(B^I)^{-1}A^I$ act on w^J according to

$$\begin{aligned} \pi(B^I)w^J &= w^J \kappa_I^{-1} (R'_{12} R'_{13} R_{13} (R'_{12})^{-1})^{IJ\bar{J}} \quad , \\ \pi((A^I)^{-1}(B^I)^{-1}A^I)w^J &= w^J \kappa_I^{-1} (R'_{12} R_{12})^{IJ\bar{J}} \quad . \end{aligned}$$

These formulas should be compared with the expressions in Theorem 15 for the representation of monodromies M_ν^I . The result can easily be generalized to the case of g handles. We find that the monodromies $M^I(l_p), p > m$, act on the summands in $\bigoplus_{\{J_i\}} \mathfrak{S}(K_1, \dots, K_m) \otimes V^{J_1} \otimes V^{\bar{J}_1} \otimes \dots \otimes V^{J_g} \otimes V^{\bar{J}_g}$ according to

$$(\kappa_I)^{-1} (K_p R'_{1(p+1)} R_{1(p+1)} K_p^{-1} \otimes e^{(m-\nu)})^{IK_1 \dots K_m J_1 \bar{J}_1 \dots J_g \bar{J}_g}$$

for all $p \leq m + 2g$. The notations were introduced in a remark after Theorem 15. With this result, the evaluation of $\hat{h}_{\nu p}$ on states is reduced to the previous case where $p \leq m$.

The evaluation of $\hat{a}_i, \hat{d}_i, \hat{e}_i$ is equally simple since the curves $x(\alpha_i), x(\delta_i), x(\epsilon_i)$ are at most products of elements $l_p, 1 \leq p \leq 2m + g$. Details of the straightforward computation are left as an exercise. Only \hat{b}_i requires some new calculation. Since $x(\beta_i) = a_i$ we need to know how $\hat{h}(a_i)$ acts on states. Let us give the answer for the handle algebra, i.e. $g = 1$ and $\hat{b} = \hat{h}(a) = \hat{h}(a_1)$. When w^J is defined as in eq. (9.8) a direct calculation establishes

$$\pi(\hat{b})w^J = \theta^{-1} \sum_K \mathcal{N} d_K v_K v_J w^K C[J\bar{J}|0](R')^{JK} (R')^{\bar{K}\bar{J}} C[K\bar{K}|0]^c \quad .$$

The generalization of this formula to g handles is obvious. This concludes the proof of the Lemma.

PROOF OF THEOREM 29: Let us recall how to obtain the Reshetikhin Turaev representation of the mapping class group. First one presents elements in the mapping class group by tangle diagrams. For our generating set of Dehn twists $\eta_{\nu p}, \alpha_i, \beta_i, \delta_i, \epsilon_i$ the corresponding diagrams can be found e.g. in [35]. Then the elements in the diagram are represented by objects associated with a Hopf algebra \mathcal{G} in the usual way (cp. also figure captions for Figure 3,4). This provides us with a set of maps between representation spaces of \mathcal{G} , one for each elements in the mapping class group.

The formulas for the action of $\hat{h}_{\nu p}, \hat{a}_i, \hat{b}_i, \hat{d}_i, \hat{e}_i$ on states of the Chern Simons theory were described by the pictures in Figure 3,4. These pictures agree with the tangle diagrams which present the corresponding elements $\eta_{\nu p}, \alpha_i, \beta_i, \delta_i, \epsilon_i$ in the pure mapping class group. In fact, only the picture for \hat{e}_i in Fig. 4 differs from the generators of the tangle algebra used in [35]. However the two pictures are equivalent up to a Kirby move [29]. Because the representation constructed above is projective, application of Kirby moves might change the result by a phase. More precisely, whenever a manipulation with tangle diagrams involves an \mathcal{O}_1 move (i.e. creation or annihilation of a closed circle \bigcirc) we have to encounter a factor $\theta^{\pm 1}$. The \mathcal{O}_2 move is respected by the representation and hence does not produce additional factors. Any manipulation that leads from our picture for \hat{e}_i to the corresponding diagram used by Matveev and Polyak involves one \mathcal{O}_1 move and thus gives rise to a factor θ . This concludes the proof of the theorem.

For the torus, the representation space \mathfrak{R} can be identified with the quantum symmetry algebra \mathcal{G} itself. Our representation π of the mapping class group on \mathfrak{R} may then be compared with formulas of Lyubashenko [32], Majid [34] and Kerler [28] for the action of mapping class groups on Hopf algebras.

10 Comments

10.1 Truncation

All the theory developed above was valid under the assumption that the symmetry algebras \mathcal{G} is semisimple. It is well known that this requirement is not satisfied for the quantum group algebras $U_q(\mathfrak{g})$ when q is a root of unity. To treat this important case we proposed (cp. [2]) to use the semisimple truncation of $U_q(\mathfrak{g})$, $q^p = 1$, which has been constructed in [33]. In this truncation, semisimplicity is gained in exchange for co-associativity, i.e. the truncated $U_q^T(\mathfrak{g})$ of [33] are only quasi-co-associative. In addition, the co-product Δ of these truncated structures is not unit preserving (i.e. $\Delta(e) \neq e \otimes e$). This leads to a generalization of Drinfeld's axioms [15] and the corresponding algebraic structures were called "weak quasi-Hopf-algebra" in [33].

Our discussions in [2] and especially in [3] provide all background information needed in dealing with nontrivial reassociators φ , i.e. if the co-product of \mathcal{G} is not co-associative. Using the "substitution rules" from [3], the above discussion

generalizes to the quasi-Hopf case without any difficulties. Let us just recall that all graph algebras become quasi-associative and only algebras $\mathcal{A}_{g,m}$ and the moduli algebras stay associative. On the other hand, the effect of the truncation $\Delta(e) \neq e \otimes e$ is much more subtle and we would like to clarify this with the following discussion. At some points throughout this paper we explicitly used the equation $\delta_I \delta_J = \sum N_K^{IJ} \delta_K$ for the dimensions δ_I of the irreducible representations τ^I . This fails to hold in the presence of truncation and we have to encounter the inequality $\delta_I \delta_J \geq \sum N_K^{IJ} \delta_K$ instead.

A first effect of such truncations is that they reduce the number of linear independent matrix elements in the quantum monodromies $M_\nu^I, A_i^I, etc.$ beyond the value of δ_I^2 . In fact one may derive the following relations

$$\tau^I(\mathcal{S}(e_\sigma^1))M^I(\mathcal{C})\tau^I(e_\sigma^2) = M^I(\mathcal{C}) \text{ with } \Delta(e) = \sum e_\sigma^1 \otimes e_\sigma^2 \ .$$

Here $M^I(\mathcal{C})$ is defined as in eq. (9.1) and may in particular be equal to A_i^I, B_i^I or M_ν^I . Let us shortly sketch the proof under the simplifying assumption that Δ is co-associative. Since the element $e \in \mathcal{G}$ is supposed to be the identity in the graph algebras, we know that $M^I(\mathcal{C}) = eM^I(\mathcal{C})$. From the covariance properties of monodromies one concludes

$$M^I(\mathcal{C}) = \tau^I(\mathcal{S}(e_{\sigma\tau}^{11}))M^I(\mathcal{C})\tau^I(e_{\sigma\tau}^{12})e_\sigma^2 \ .$$

This formula is used twice in the following calculation

$$\begin{aligned} & \tau^I(\mathcal{S}(e_\rho^1))M^I(\mathcal{C})\tau^I(e_\rho^2) \\ &= \tau^I(\mathcal{S}(e_\rho^1))\tau^I(\mathcal{S}(e_{\sigma\tau}^{11}))M^I(\mathcal{C})\tau^I(e_{\sigma\tau}^{12})\tau^I(e_\rho^2)e_\sigma^2 \\ &= \tau^I(\mathcal{S}(e_{\sigma\tau}^{11}))M^I(\mathcal{C})\tau^I(e_{\sigma\tau}^{12})e_\sigma^2 = M^I(\mathcal{C}) \ . \end{aligned}$$

The second step simply follows from $\Delta(e)\Delta(\xi) = \Delta(e\xi) = \Delta(\xi)$. We conclude that $M^I(\mathcal{C})$ contains only $N_K^{IJ} \delta_K \leq \delta_I^2$ linear independent components. The total dimension of the algebra $\mathcal{L}(M^I(\mathcal{C}))$ generated by matrix components of $M^I(\mathcal{C})$ is then $\sum_{I,K} N_K^{IJ} \delta_K$.

With respect to Lemma 1, this remark shows that we cannot expect all linear maps in $End(V^J)$ to appear in the image of quantum monodromies under the representations D^J . However, a careful reexamination of the proof shows that the faithfulness of the representation theory is still guaranteed. Indeed the same proof allows us to find $\sum N_K^{IJ} \delta_K$ linear independent representation matrices on a space V^I . The sum of these numbers over I coincides with the dimension of the the (quasi-associative) loop algebra \mathcal{L} (cp. preceding paragraph).

All the proofs we gave in the Section on the genus 0 case were designed so that they only use the faithfulness. They now carry over to the truncated situation. Let us emphasize that the irreducibility of representations is not completely lost. We saw above counting arguments prevent the representations D^I of the loop

algebra \mathcal{L} from being irreducible. The same holds true for the multi-loop case. However, when we descent to moduli algebras, counting arguments allow to derive irreducibility of the representation theory from the faithfulness much as this was done in Section 6.3. So the general rule is that irreducibility statements fail on the level of graph algebras but hold again on the level of moduli algebras.

There is a similar story about handle algebras. We continue to generate the representation space \mathfrak{R} from a ground state $|0\rangle$ by application of the “creation operators” A^I . From our discussion above, the resulting space has the same dimension as the loop algebra $\mathcal{L}(A)$ associated with monodromies A^I , i.e. we find $\dim(\mathfrak{R}) = \sum_{I,K} N_K^{II} \delta_K$. In particular, the space \mathfrak{R} is no longer isomorphic to $\bigoplus_I V^I \otimes V^{\bar{I}}$. We may, however, write $\mathfrak{R} \cong \bigoplus (V^I \otimes V^{\bar{I}})'$ where $(V^I \otimes V^{\bar{I}})'$ is the subspace of $V^I \otimes V^{\bar{I}}$ on which $D(e)^{II}$ acts as identity. Our proof at the end of Subsection 7.3 shows that the representations π of the handle algebra \mathcal{T} is still irreducible. In fact, the projectors χ_B^I now project to the $\sum_K N_K^{II} \delta_K$ -dimensional subspace $(V^I \otimes V^{\bar{I}})'$ of \mathfrak{R} . Monodromies B^J and $(A^J)^{-1}(B^J)^{-1}A^J$ give rise to $(\sum_K N_K^{II} \delta_K)^2$ linear independent maps on $(V^I \otimes V^{\bar{I}})'$. So we obtain a full matrix algebra over this subspace. Irreducibility of π is then obtained as before. Faithfulness of the representation follows from irreducibility by the usual counting of dimensions. From this point on, the rest of the discussion – in particular the representation theory at higher genera – is straightforward.

These remarks suffice to generalize the above theory to weak quasi Hopf algebras and hence to open the way for its application to interesting symmetry algebras associated with $U_q(\mathfrak{g})$, $q^p = 1$.

10.2 Open problems

In this paper we essentially completed the program of operator quantization of the Chern-Simons theory. We have defined the algebra of observables equipped with the $*$ -operation and the positive integration functional and developed its representation theory. It is shown that the list of irreducible unitary representations matches with the Hilbert spaces produced by Geometric Quantization of the moduli space of flat connections.

Let us mention here several open problems related to the framework of Combinatorial Quantization.

We mentioned in Section 4 that for generic values of q the moduli algebra $\mathcal{M}_{g,m}^{\{I_\nu\}}$ is isomorphic (as a linear space) to the classical algebra of analytic functions on the moduli space of flat connections. Eventually, these spaces may be identified in many ways. However, we can restrict the choice by the following condition. Pick up some circle x on the surface. Corresponding to this circle one can construct (see Section 9) a set of elements $c^I(x) \in \mathcal{M}_{g,m}^{\{I_\nu\}}$ via

$$c^I(x) = \kappa_I \text{tr}_q M^I(x). \quad (10.1)$$

The representations of the quantum symmetry algebra for generic q being in one

to one correspondence with the representation of the group G , one can construct classical counterparts of elements (10.1):

$$c_0^I(x) = \text{tr} M^I(x). \quad (10.2)$$

These are already commuting analytic functions on the moduli space.

So, one wishes to construct the map \mathcal{Q} which maps classical functions into the elements of the moduli algebra so that

$$\mathcal{Q}(c_0^I(x)) = c^I(x) \quad (10.3)$$

for every x and I . It is not *a priori* clear that such a map exists. At least we wish to preserve (10.3) for sufficiently many cycles on the surface.

Another conceptual problem related to the quantized moduli space is the issue of a differential calculus. The classical moduli space has a rich cohomology theory [44], [25]. From this perspective it would be interesting to define the corresponding cohomology problem for quantized moduli spaces. One can hope that the differential calculi on the quantum groups may provide a good starting point.

Acknowledgements: We would like to thank S. Axelrod, G. Felder, E. Frenkel, K. Gawedzki, T. Kerler, N. Reshetikhin, and J. Roberts for comments and discussions. The work of V.S. was partly supported by the Department of Energy under DOE Grant No. DE-FG02-88ER25065.

References

- [1] A. Yu. Alekseev, L.D.Faddeev, M.A.Semenov-Tian-Shansky *Hidden Quantum groups inside Kac-Moody algebras*, Commun. Math. Phys. **149**, no.2 (1992) p.335
- [2] A. Yu. Alekseev, H. Grosse, V. Schomerus, *Combinatorial quantization of the Hamiltonian Chern Simons theory I*, HUTMP 94-B336, Commun. Math. Phys., to appear
- [3] A. Yu. Alekseev, H. Grosse, V. Schomerus, *Combinatorial quantization of the Hamiltonian Chern Simons theory II*, HUTMP 94-B336, Commun. Math. Phys., to appear
- [4] A. Yu. Alekseev, V. Schomerus, *Mapping class groups and moduli algebras*, in preparation
- [5] A. Yu. Alekseev, *Integrability in the Hamiltonian Chern-Simons theory*, hep-th/9311074, St.-Petersburg Math. J. **vol. 6** 2 (1994) 1

- [6] D. Altschuler, A. Coste *Quasi-quantum groups, knots, three manifolds and topological field theory*, Commun. Math. Phys. **150** (1992) 83
- [7] J. Andersen, J. Mattes, N. Reshetikhin *Poisson structure on the moduli space of flat connections and chord diagrams*, in preparation;
Quantization of the algebra of chord diagrams, in preparation
- [8] M. Atiyah, R. Bott, *The Yang-Mills equation over Riemann surfaces*, Phil. Trans. of the Royal Soc. of London, Ser A **308** (1982) 523
- [9] S. Axelrod, S. Della Pietra, E. Witten, *Geometric quantization of Chern-Simons gauge theory*, J. Diff. Geom. **33** (1991) 787
- [10] S. Axelrod, I.M. Singer, *Chern-Simons Perturbation Theory II*, preprint HEP-TH/9304087.
- [11] D.V. Boulatov, *q-deformed lattice gauge theory and three manifold invariants*, Int. J. Mod. Phys. **A8**,(1993), 3139
- [12] E. Buffenoir, Ph. Roche, *Two dimensional lattice gauge theory based on a quantum group*, preprint CPTH A 302-05/94 and hep-th/9405126
- [13] DeConcini, V. Kac *Representations of quantum groups at roots of 1*, in *Progress in Mathematics* vol. **92**, Birkhäuser 1990.
- [14] V.G. Drinfel'd, *Quantum groups*, Proc. ICM (1987) 798
- [15] V.G. Drinfel'd, *Quasi Hopf algebras and Knizhnik Zamolodchikov equations*, in: Problems of modern quantum field theory, Proceedings Alushta 1989, Research reports in physics, Springer Verlag Heidelberg 1989
V.G. Drinfel'd, *Quasi-Hopf algebras*, Leningrad. Math. J. Vol. **1** (1990), No. 6
- [16] B. Durhuus, H.P. Jakobsen, R. Nest, *A construction of topological quantum field theories from 6j-symbols*, Nucl. Phys. B (Proc. Suppl.) (1991), 666
- [17] S. Elitzur, G. Moore, A. Schwimmer, N. Seiberg, *Remarks on the canonical quantization of the Chern-Simons-Witten theory*, Nucl. Phys. **326**, (1989), 108
- [18] L.D. Faddeev, N. Yu. Reshetikhin, L.A. Takhtadzhyan, *Quantization of Lie Groups and Lie Algebras*, Algebra and Analysis **1** (1989), 1 and Leningrad Math. J. Vol. 1 (1990), No. 1
- [19] B.V. Fedosov, *Formal quantization*, Some topics of modern Mathematics and their application to problems in Mathematical Physics, Moscow (1985), 129;
A simple geometrical construction of deformation quantization, J. Diff. Geom., to appear

- [20] M.Finkelberg, *Fusion Categories*, Harvard University thesis, May 1993
- [21] V.V. Fock, A.A. Rosly, *Poisson structures on moduli of flat connections on Riemann surfaces and r-matrices*, preprint ITEP 72-92, June 1992, Moscow
- [22] J. Fröhlich, F. Gabbiani, *Braid statistics in local quantum theory*, Rev. Math. Phys. **2** (1991) 251
- [23] W. Goldman *Invariant functions on Lie groups and Hamiltonian flows of surface group representations*, Invent. Math. **85** (1986) 263;
The symplectic nature of fundamental groups of surfaces, Adv. Math. **54** (1984) 200
- [24] F.M. Goodman, P. de la Harpe, V.F.R. Jones *Coxeter graphs and towers of algebras*, Springer Verlag, 1989
- [25] L.Jeffrey, F.Kirwan, talk given at Newton Institute, Cambridge, November 1994.
- [26] M. Karowski, R. Schrader, *A combinatorial approach to topological quantum field theories and invariants of graphs*, Commun. Math. Phys. **151**, (1993), 355
M. Karowski, R. Schrader, *A quantum group version of quantum gauge theories in two dimensions*, J. Phys. **A 25**, (1992), L1151
- [27] D. Kazhdan, G. Lusztig, *Tensor structures arising from affine Lie algebras I/II*, J. Am. Math. Soc. **vol. 6** 4 (1993) 905
- [28] T. Kerler, *Mapping class group actions on quantum doubles*, Commun. Math. Phys., to appear
- [29] R. Kirby, *A calculus for framed links in S^3* , Invent. Math. **45** (1978) 35
- [30] V. Knizhnik, A. B. Zamolodchikov, *Current algebra and Wess-Zumino model in two dimensions*, Nucl. Phys. **B247** (1984) 83
- [31] Lusztig, *Finite dimensional Hopf algebras arising from quantized universal enveloping algebras* J. Am. Math. Soc. **vol. 3** 1 (1990) 257
- [32] V. Lyubashenko, *Tangles and Hopf algebras in braided tensor categories*, J. Pure Appl. Alg., to appear
- [33] G. Mack, V. Schomerus, *Quasi Hopf quantum symmetry in quantum theory*, Nucl. Phys. **B370**(1992),185
- [34] S. Majid, *Braided groups*, J. Pure Appl. Alg. **86** (1993) 187
- [35] S. Matveev, M. Polyak, *A geometrical presentation of the surface mapping class group and surgery*, Commun. Math. Phys. **160** (1994)

- [36] N. Reshetikhin, M. Semenov-Tian-Shansky, , Lett. Math. Phys. **19** (1990) 133
- [37] N. Reshetikhin, V. G. Turaev, *Ribbon graphs and their invariants derived from quantum groups*, Commun. Math. Phys. **127**, (1990),1
- [38] N. Reshetikhin, V. G. Turaev, *Invariants of 3-manifolds via link polynomials and quantum groups*, Invent. Math. **103** (1991) 547
- [39] A. Sudbury, *Non-commuting coordinates and differential operators* in: Quantum groups, T. Curtright et al. (eds), World Scientific, Singapore 1991
- [40] V. Turaev, *Skein quantization of Poisson algebras of loops on surfaces*, Ann. scient. Ec. Norm. Sup. 4e serie, t. 24 (1991) 635
- [41] V.G. Turaev, O.Y. Viro, *State sum of 3-manifolds and quantum 6j-symbols*, LOMI preprint (1990)
- [42] E. Verlinde, *Fusion rules and modular transformations in 2D conformal field theory*, Nucl. Phys. **B 300** (1988) 360
- [43] E.Witten, *Quantum field theory and the Jones polynomial*, Commun. Math. Phys. **121**, (1989),351
- [44] E.Witten, *Two-dimensional gauge theory revisited*, J. Geom. Phys. **9** (1992) 303