

OPERADS AND ALGEBRAIC COMBINATORICS OF TREES

F. CHAPOTON

ABSTRACT. This text is an introduction to operads from a combinatorial point of view. We give the definition, several examples of operads and the construction of a group from each operad.

1. INTRODUCTION

Combinatorics is concerned with finite objects, and considers problems such as enumerating some finite sets or finding bijections between different sets. Algebraic combinatorics could be defined as the reciprocal application of methods and ideas of algebra to combinatorics or the other way round. Since the pioneering work of Rota “on the foundations of combinatorial theory”, these subjects have become an active and central piece of mathematics.

Up to now, most of the algebraic structures used in algebraic combinatorics have been well-established and classical notions of algebra. One of the main streams is the use of associative algebras and their representation theory, where combinatorial objects appear typically as labelling sets for some basis, or in a description of some modules. For instance, partitions, as considered in number theory, play an important role in representation theory of symmetric groups, general linear groups and many related algebras.

Similarly, there has been recently a lot of activity on relations between Hopf algebras and combinatorial objects. One salient point of these works is the appearance of new kinds of combinatorial entities, such as different kinds of trees, in an algebraic context.

The present text would like to advocate for the potential use in combinatorics of a more recent algebraic notion, which is called an operad. This notion has first been introduced in algebraic topology in the early 1970’s (Boardman–Vogt, May [BV73, May72]) for the study of loop spaces. There was a “renaissance”, a renewed interest in operads, in the 1990’s, with the Koszul duality theory introduced by Ginzburg and Kapranov [GK94] and also in relation with moduli spaces of curves [LSV97]. More recently, the theory of operads has seen further developments in many directions. Operads are useful to describe and work with complicated new kinds of algebras and algebras up to homotopy.

The idea of an operad is closely related to trees, in a similar sense that the idea of an associative algebra is related to the notion of words. Operads could be useful in combinatorics in several ways. First, they can shed light on some classical combinatorial objects, by endowing them with new algebraic structures, much like associative algebras do for partitions. Next, they can provide the setting for very refined versions of generating series, where the indices are no longer the set of integers, but some set of combinatorial objects, such as trees of various sorts.

We have tried to present the theory of operads to a combinatorial audience, by a specific choice of illustrative examples. The combinatorialist who already knows something about the combinatorial theory of species of structures of Joyal [Joy86] (which aims at providing a way to deal with generating series in some universal way) will see it appear from another point of view.

Let us give some further general references on operads: a general presentation [Lod96] and two monographs [MSS02, Smi01].

This text is the written version of lectures given at the 58th Séminaire Lotharingien de Combinatoire in March 2007. We give several equivalent definitions of operads, examples of operads based on combinatorial objects, and explain how one can build a group of “invertible formal power series” starting from an operad.

2. MOTIVATION

This section explains briefly some possible motivations for operads in combinatorics.

2.1. Words and permutations. Let us recall the classical relation between **words** and **associativity**.

An alphabet A is a set of letters $\{a, b, c, \dots\}$. A word w in the alphabet A is a sequence of letters $w = (w_1, w_2, \dots, w_k)$. There is a basic operation on words given by concatenation, which is associative. In fact, the set of words is exactly the free associative monoid on the set A . So the study of words naturally takes place in the setting of associative algebras.

Consider now the alphabet $\{a_1, \dots, a_n\}$. Then the set of words where each letter a_i appears exactly once can be seen as the set of **permutations** of $\{1, \dots, n\}$. In a natural sense, permutations encode all possible operations that can be made with n distinct elements in an associative algebra.

One can find a similar relation between some kinds of trees and some new kinds of algebraic structures. There is a parallel between

- words or permutations \longleftrightarrow associative algebras,
- rooted trees \longleftrightarrow pre-Lie algebras,
- planar binary trees \longleftrightarrow dendriform algebras.

The natural setting of these generalisations is the theory of **operads**, which permits to work with different “types of algebras.”

2.2. Partitions. Integer partitions are classical in combinatorics and are important too in representation theory.

The Hopf algebra of symmetric functions [Mac95] can be seen as a description of representations of symmetric groups. To each integer partition of an integer n correspond an isomorphism class of modules over the symmetric group \mathfrak{S}_n .

The set of planar binary trees has also such a dual nature.

- partitions \longleftrightarrow modules over the symmetric groups,
- planar binary trees \longleftrightarrow tilting modules on quivers of type A.

There is a natural and simple bijection (see [Hil06]) between planar binary trees and tilting modules over the following quivers:

$$1 \rightarrow 2 \rightarrow 3 \rightarrow \cdots \rightarrow n. \quad (1)$$

One further hint of the importance of this relation between planar binary trees and tilting modules is given by the frequent occurrence of the Tamari lattice in algebraic structures on planar binary trees, together with the fact that this poset has a natural definition in terms of tilting modules.

2.3. Grafting, cutting, pruning, gluing, etc. Algebraic structures on trees did already appear a long time ago, for instance in the work of Butcher [But72] in numerical analysis.

Many new algebraic structures on trees have been introduced more recently, notably by Connes and Kreimer [CK98]. Among them, one can find

- Hopf algebras,
- Lie algebras,
- groups,
- operads.

Operads sometimes provide a way to understand all these objects, or at least they provide a valuable point of view.

On the other hand, trees are obviously used everywhere in combinatorics. For example, there are

- many posets on some sets of trees [Pit99, HT72],
- different statistics on trees (like on permutations),
- some bijections or morphisms between trees and permutations,
- proofs of Lagrange inversion using trees [Lab81].

One could also cite the many studies of random trees, and the uses of the generating series of rooted trees (the Lambert W function [CGH⁺96]), for instance in the study of random graphs and parking functions.

In these lectures we will concentrate on two particularly nice kinds of trees:

- rooted trees,
- planar binary trees.

For each of them, we will introduce two different operads.

2.4. Four flavours of operads. One has to distinguish four kinds of operads: either we work

- in the category of sets or
- in the category of vector spaces,

and also either with

- symmetric or labelled (with actions of symmetric groups) or
- non-symmetric or unlabelled (without actions of symmetric groups)

objects.

This second dichotomy corresponds also (in some sense) to non-planar or planar trees.

We will consider examples of operads of all four kinds. Let us present a summary here:

- In Set, non-symmetric: Associative, OverUnder
- In Set, symmetric: Commutative, NAP
- In Vect, non-symmetric: Dendriform, M (standing for Mould)
- In Vect, symmetric: pre-Lie

3. NON-SYMMETRIC OPERADS

In this section, the notion of a non-symmetric operad is introduced, first in the category of sets, then in the category of vector spaces. We give two different definitions and explain how they are related one to each other.

3.1. Non-symmetric operads in the category of sets. Let us consider the category Set endowed with the Cartesian product \times . In fact, we will consider here only finite sets, but this is not a necessary condition.

There are two flavours of operads in Set, depending on the presence or not of actions of symmetric groups. Let us start with the simplest case, without actions of symmetric groups.

Definition 1. *A non-symmetric operad \mathcal{P} in Set is the data of a set $\mathcal{P}(n)$ for each integer $n \geq 1$, of an element $\mathbf{1}$ in $\mathcal{P}(1)$ and of composition maps*

$$\gamma : \mathcal{P}(m) \times \mathcal{P}(n_1) \times \cdots \times \mathcal{P}(n_m) \longrightarrow \mathcal{P}(n_1 + \cdots + n_m) \quad (2)$$

for all integers m, n_1, \dots, n_m .

These data have to satisfy the following conditions.

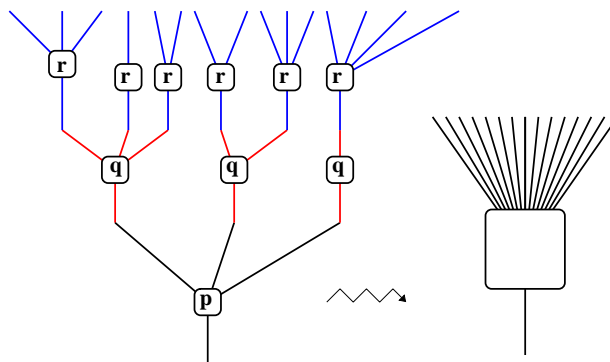

FIGURE 1. Main axiom for composition. First composing q 's and r 's then composing p and the result is the same as first composing p and q 's then composing the result and r 's. The common result is symbolically depicted on the right.

The element $\mathbf{1}$ is a unit in the following sense:

$$\gamma(\mathbf{1}; p) = p \tag{3}$$

$$\gamma(p; \mathbf{1}, \dots, \mathbf{1}) = p, \tag{4}$$

for all $p \in \mathcal{P}(n)$.

The composition maps γ satisfy the following associativity condition:

$$\begin{aligned} \gamma(\gamma(p; q_1, \dots, q_n); r_{1,1}, \dots, r_{1,m_1}, r_{2,1}, \dots, r_{2,m_2}, r_{3,1}, \dots, r_{n,m_n}) \\ = \gamma(p; \gamma(q_1; r_{1,1}, \dots, r_{1,m_1}), \dots, \gamma(q_n; r_{n,1}, \dots, r_{n,m_n})). \end{aligned}$$

This means that there are two ways to perform composition in Fig. 1, either starting with several top compositions or starting with one bottom composition; these two maps should give the same result.

One way to recall easily these axioms is to think of the set $\mathcal{P}(n)$ as being a set of operations with n (ordered) inputs and one output. Such an operation can be symbolically depicted as in Fig. 1 by a box with one outgoing and n incoming legs.

Note that non-symmetric operads form a category, with the expected notion of morphism f from \mathcal{P} to \mathcal{Q} , given by one map f_n from $\mathcal{P}(n)$ to $\mathcal{Q}(n)$ for each n , which have to be compatible with the composition maps, in the sense that the obvious diagrams must commute.

3.2. Planar binary trees. Let us give an example, not the simplest possible but rather a more interesting one. For this, we need some classical combinatorial objects.

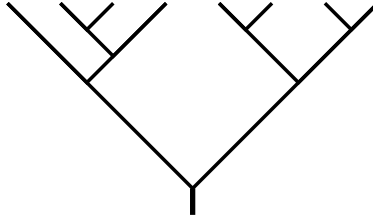

FIGURE 2. A planar binary tree.

A *planar binary tree* is a finite connected and simply connected graph, having only vertices of degree 1 or 3, embedded in the plane, and with a distinguished vertex of degree 1 called the root. The other vertices of degree 1 are called the leaves. The vertices of degree 3 will from now on simply be called vertices.

There is a standard way to draw such trees: leaves are on a horizontal line on top with a regular spacing and edges are in diagonal directions.

Given a planar binary tree T with n vertices, one can number its vertices from 1 to n in a canonical way, with a recursive definition. First number the vertices of the left part of the tree from 1 to $k - 1$, then the bottom vertex with k and the vertices of the right part of the tree from $k + 1$ to n .

The number of planar binary trees with n vertices is the Catalan number

$$c_n = \frac{1}{n+1} \binom{2n}{n}. \quad (5)$$

Stanley [Sta97] has given at least 143 different combinatorial interpretations of the Catalan numbers, among which one can cite Dyck paths, planar trees, nonnesting and noncrossing partitions.

Recently, many relations have been found between objects counted by the Catalan numbers and structures in algebra and representation theory: quasi-symmetric functions [AB03, ABB04], cluster algebras [FZ03], cluster tilting theory [BMR⁺06], dual braid monoid [Bes03], Hopf algebras [LR02], etc.

3.3. The OverUnder operad. Here comes the first example of a (non-symmetric) operad, called the OverUnder operad OU (also called Duplicial operad). It is used by Frabetti [Fra08] in her work on renormalization with planar binary trees.

The set $\text{OU}(n)$ is the set of planar binary trees with $n + 1$ leaves.

The unit $\mathbf{1}$ in $\text{OU}(1)$ is the only planar binary tree $\begin{array}{c} \diagup \\ \diagdown \end{array}$ with one vertex.

Composition is given by **local substitution** at each inner vertex. One uses the canonical numbering of inner vertices introduced above. Then given n planar binary trees S_1, \dots, S_n , the composition $\gamma(T; S_1, \dots, S_n)$ is obtained by replacing a neighbourhood of each vertex i of T by the planar binary tree S_i , identifying

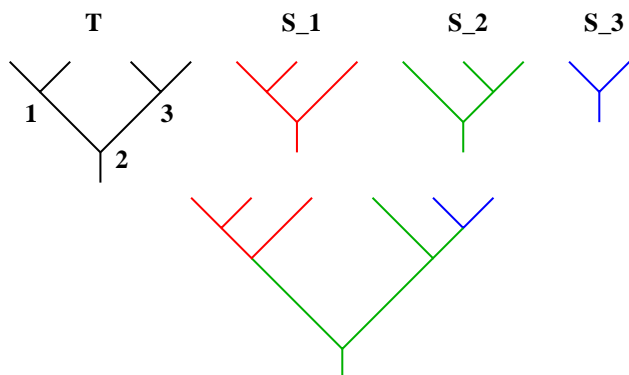

FIGURE 3. Example of composition in the OU operad.

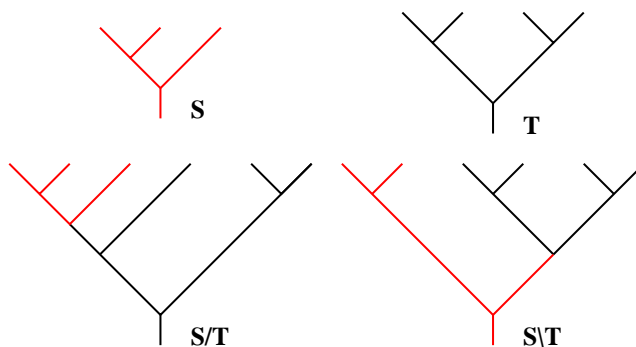

FIGURE 4. Example for the / and \ associative products.

the leftmost leaf of S_i with the edge \backslash emanating from i and the rightmost leaf of S_i with the edge $/$ emanating from i .

Figure 3 displays the composition

$$\gamma(T; S_1, S_2, S_3). \tag{6}$$

One has two simple associative operations on planar binary trees: the over ($/$) and under (\backslash) products.

The over product S/T is obtained by grafting the root of S on the leftmost leaf of T .

The under product $S\backslash T$ is obtained by grafting the root of T on the rightmost leaf of S .

In addition to being both associative, the over and under products satisfy

$$(x/y)\backslash z = x/(y\backslash z). \tag{7}$$

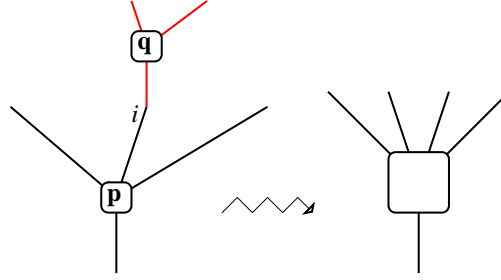
FIGURE 5. A simple composition $p \circ_i q$.

3.4. Alternative axiomatics. There is an alternative presentation of the notion of a non-symmetric operad.

Instead of being given by γ maps, the composition is described by maps \circ_i . The γ map is to be thought of as simultaneous insertion of several objects into one, the \circ_i as the insertion of just one object into another one.

- (1) γ maps \longleftrightarrow simultaneous composition,
- (2) \circ_i map \longleftrightarrow simple composition.

So instead of maps γ as before, we are given a collection of maps \circ_i for all m, n and $1 \leq i \leq m$ from $\mathcal{P}(m) \times \mathcal{P}(n) \rightarrow \mathcal{P}(m+n-1)$.

The \circ_i maps have to satisfy an associativity and a commutativity axiom.

Let x, y, z be in $\mathcal{P}(m), \mathcal{P}(n), \mathcal{P}(p)$ respectively.

- Associativity I (Disjoint composition): $(x \circ_i y) \circ_{j+n-1} z = (x \circ_j z) \circ_i y$ for all x, y, z and $i < j$ in $\{1, \dots, m\}$,
- Associativity II (Nested composition): $(x \circ_i y) \circ_{j+i-1} z = x \circ_i (y \circ_j z)$ for all x, y, z, i in $\{1, \dots, m\}$ and j in $\{1, \dots, n\}$,
- Unit: $\mathbf{1} \circ_1 x = x = x \circ_i \mathbf{1}$ for all $m, i = 1, \dots, m$.

The equivalence between the two presentations is obtained by using the unit $\mathbf{1}$.

In one way, the \circ_i maps can be defined directly from the γ maps:

$$x \circ_i y = \gamma(x; \mathbf{1}, \dots, \mathbf{1}, y, \mathbf{1}, \dots, \mathbf{1}), \quad (8)$$

where y is in the i^{th} position.

In the other way, the γ maps can be recovered by iteration of the \circ_i maps:

$$\gamma(p; q_1, \dots, q_n) = (\dots ((p \circ_n q_n) \circ_{n-1} q_{n-1}) \cdots \circ_1 q_1). \quad (9)$$

3.5. The operad of endomorphisms of a set. If S is a set, one can define the endomorphism operad of S (denoted by End_S) as the collection $\text{End}_S(n) = \text{Hom}(S^n, S)$ together with the usual composition of multiple maps. For instance, the simple composition of $f \in \text{End}_S(m)$ and $g \in \text{End}_S(n)$ at position i is

$$(f \circ_i g)(s_1, \dots, s_{m+n-1}) = f(s_1, \dots, g(s_i, \dots, s_{i+n-1}), \dots, s_{m+n-1}). \quad (10)$$

The unit $\mathbf{1}$ is the identity in $\text{End}_S(1)$.

If you are given a morphism from another operad \mathcal{P} to End_S , then one says that S has the structure of an **algebra over the operad \mathcal{P}** .

For instance, one can show that an algebra over the OU operad is exactly a set endowed with two associative operations $/$ and \backslash satisfying $(x/y)\backslash z = x/(y\backslash z)$. This amounts to finding a presentation of the OU operad as a quotient of a free operad.

3.6. The Associative operad. Here comes another example of a non-symmetric operad, a very simple and essential one.

The set $\text{Assoc}(n)$ is just a singleton $\{M_n\}$. The unit $\mathbf{1}$ is M_1 . The composition is defined by

$$M_m \circ_i M_n = M_{m+n-1} \tag{11}$$

or by

$$\gamma(M_n; M_{k_1}, \dots, M_{k_n}) = M_{k_1 + \dots + k_n}. \tag{12}$$

This operad has a presentation by generators and relations: it is generated by M_2 and the unique relation is

$$\gamma(M_2; M_2, \mathbf{1}) = \gamma(M_2; \mathbf{1}, M_2). \tag{13}$$

This means that a morphism from Assoc to End_S is determined by the image of M_2 , which is a map from $S \times S \rightarrow S$ that has to be associative in the usual sense.

3.7. Free operads. Let us define the free non-symmetric operad generated by a collection of sets $G = (G_k)_{k \geq 2}$.

A *planar rooted tree* is a finite graph which is a tree, with a distinguished vertex of degree one (the root), together with an embedding in the plane. Other vertices of degree one are called leaves.

The set $\text{Free}_G(n)$ is the set of planar rooted trees with n leaves and with labelled inner vertices. Inner vertices must have degree at least 3, and vertices of degree $k + 1$ must be labelled by elements of G_k for $k \geq 2$.

The unit $\mathbf{1}$ is the planar rooted tree without any inner vertex, with just a leaf and a root.

Composition is given by **grafting** of leaves with roots.

Figure 6 displays the composition

$$\gamma(T; S_1, S_2, S_3) \tag{14}$$

in a free operad.

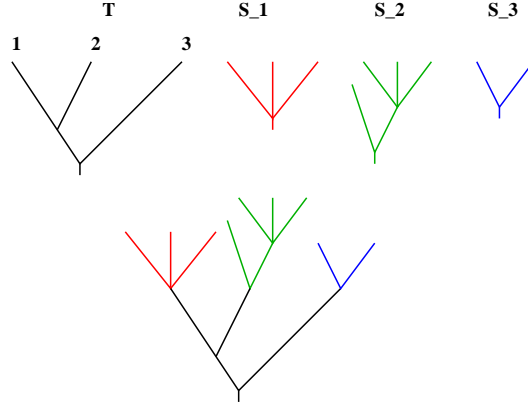

FIGURE 6. Example of composition in a free operad.

3.8. Non-symmetric operads in the category of vector spaces. Many classical operads can not be defined in the category of sets, but only in the category of vector spaces.

The definition is just the same,

- Sets $\mathcal{P}(n) \longleftrightarrow$ Vector spaces $\mathcal{P}(n)$,
- Cartesian product $\times \longleftrightarrow$ tensor product \otimes ,
- Disjoint union $\sqcup \longleftrightarrow$ direct sum \oplus ,
- maps \longleftrightarrow linear maps.

One can go from a non-symmetric operad in Set to a non-symmetric operad in Vect simply by using the functor “free vector space over a set”.

The combinatorial aspect can survive if there is a nice basis in each vector space $\mathcal{P}(n)$ and a clean description of the composition maps in these bases.

3.9. The Dendriform operad. The dendriform operad Dend has been introduced by Loday [Lod01]. The initial motivation was from algebraic topology.

The free dendriform algebra on one generator has a basis indexed by planar binary trees. It is endowed with an associative product denoted by $*$, which is the sum of two dendriform products.

Later, Loday and Ronco introduced a Hopf algebra on the free dendriform algebra on one generator [LR02]. This is now called the Hopf algebra of planar binary trees or Loday-Ronco Hopf algebra.

The vector space $\text{Dend}(n)$ has a basis indexed by planar binary trees with n vertices.

The unit $\mathbf{1}$ in $\text{Dend}(1)$ is the tree \vee .

Composition has a combinatorial description using **pairs of shuffles**, that we will not describe precisely here. In the composition $T \circ_i S$, one has to identify the

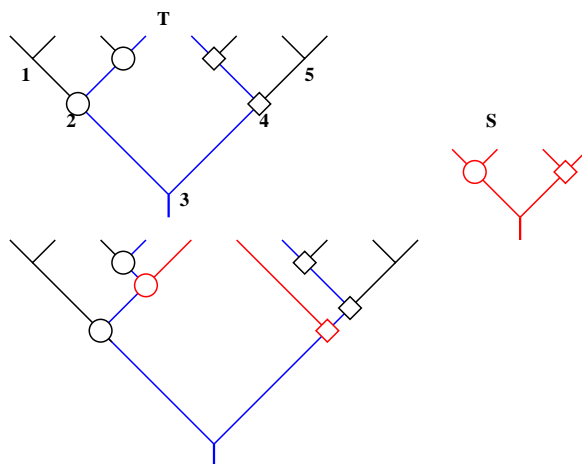

FIGURE 7. One term in the composition $T \circ_3 S$ in the Dend operad.

left hand side of S with one specific path in T and the right hand side of S with another path in T . Each of these two identifications is given by a shuffle.

More recently, it has been shown [Cha05] that the dendriform operad has a more refined structure: it is an **anticyclic operad**. For the precise definition of what anticyclic and cyclic operads are, the reader may consult [GK95].

This implies in particular that there is a natural action of the cyclic group $\mathbb{Z}/(n+1)\mathbb{Z}$ on the vector space $\text{Dend}(n)$. Let us say a little bit more on this interesting action.

The matrices of the generator of the cyclic group action on $\text{Dend}(2)$ and $\text{Dend}(3)$, in the bases $\left\{ \begin{array}{c} \diagdown \\ \diagup \end{array} , \begin{array}{c} \diagup \\ \diagdown \end{array} \right\}$ and $\left\{ \begin{array}{c} \diagdown \\ \diagdown \\ \diagup \end{array} , \begin{array}{c} \diagdown \\ \diagup \\ \diagdown \end{array} , \begin{array}{c} \diagup \\ \diagdown \\ \diagup \end{array} , \begin{array}{c} \diagup \\ \diagup \\ \diagdown \end{array} , \begin{array}{c} \diagdown \\ \diagup \\ \diagup \end{array} \right\}$, are as follows:

$$\begin{bmatrix} -1 & 1 \\ -1 & 0 \end{bmatrix} \text{ and } \begin{bmatrix} -1 & 0 & 1 & 1 & -1 \\ -1 & 0 & 1 & 0 & 0 \\ 0 & -1 & 0 & 1 & 0 \\ -1 & 0 & 0 & 0 & 0 \\ 0 & -1 & 0 & 0 & 0 \end{bmatrix} \tag{15}$$

One can see that this action is not given by a permutation of the set of planar binary trees.

Let us now explain one way to understand this action. There is a natural map from planar binary trees to rational functions, which goes as follows.

Let us fix an integer n and n indeterminates $\{u_1, \dots, u_n\}$.

Then a planar binary tree T defines a set of intervals in $\{1, \dots, n\}$: to each inner vertex corresponds a pair of leaves (the leftmost and rightmost ones among the leaves that are above this vertex in T) and these leaves enclose an interval.

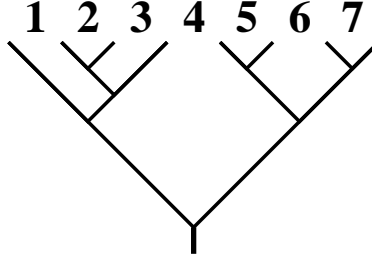

FIGURE 8. A planar binary tree and its standard numbering.

The planar binary tree T is mapped to

$$\frac{1}{\prod_I \sum_{i \in I} u_i}, \quad (16)$$

where the product runs over the set of intervals defined by T .

For example, the planar binary tree shown in Fig. 8 is mapped to

$$\frac{1}{(u_1 + u_2 + u_3)(u_2)(u_2 + u_3)(u_1 + \cdots + u_7)(u_5)(u_5 + u_6 + u_7)(u_7)}.$$

It is clear that this map is an injective map from the set of planar binary trees to the set of rational functions: just factorise the fraction to recover the tree. Less obviously, the associated linear map is also injective.

All this is related to the work of Ecalle [Eca03] and the notion of a **mould**. There exists an operad M introduced in [Cha07], whose component $M(n)$ is the field $\mathbb{Q}(u_1, \dots, u_n)$ of rational functions in n indeterminates.

Theorem 3.1. *The map introduced above defines an injective map of the Dendriform operad into the operad M .*

On the fractions, there is also an action of the cyclic group $\mathbb{Z}/(n+1)\mathbb{Z}$ given by substitution

$$u_i \mapsto u_{i-1} \text{ and } u_1 \mapsto -(u_1 + \cdots + u_n). \quad (17)$$

This is compatible with the injection and gives back the cyclic action on planar binary trees.

3.10. Non-crossing trees. One can use this map into fractions to describe a subset of Dend which is closed under composition. Consider a regular polygon with $n+1$ vertices. Assume that there is a distinguished side called the **base**. Recall that a non-crossing tree is a set of diagonals between vertices of this polygon such that

- No two of them intersect,
- all vertices are connected by these diagonals,

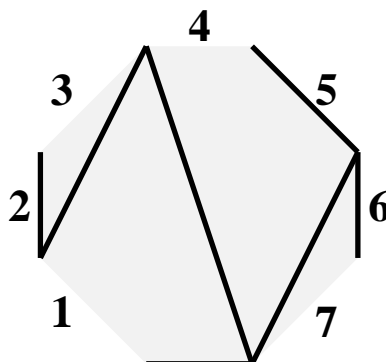

FIGURE 9. A non-crossing tree

- there are no cycles.

We will furthermore assume that it contains the base.

The number of such trees is [Noy98]

$$\frac{1}{n} \binom{3n-2}{2n-1}. \tag{18}$$

There is a simple map from non-crossing trees to rational functions. The fraction is the inverse of the product of terms corresponding to diagonals. A diagonal is mapped to the sum $\sum_{i \in I} u_i$, where I is the set of sides of the polygon that are separated from the base side by the chosen diagonal.

For example, the non-crossing tree shown in Fig. 9 is mapped to

$$\frac{1}{(u_2)(u_2 + u_3)(u_1 + \dots + u_7)(u_5)(u_6)(u_4 + u_5 + u_6 + u_7)(u_6 + u_7)}.$$

There is an operad on non-crossing trees. The unit **1** is the unique tree in the 2-polygon.

Composition is given by **gluing** the base side of one tree along a chosen side of the other one, then removing the base in order to avoid creating a cycle.

By mapping non-crossing trees to fractions (this is injective), one gets fractions which are in the image of Dend. Hence non-crossing trees can be seen as a sub-operad of the operad Dend.

4. SYMMETRIC OPERADS

Symmetric operads are slightly more complicated than non-symmetric operads. Instead of being given a collection of sets indexed by the integers, the underlying data is a **species**.

4.1. Species. The theory of **species** has been introduced by Joyal [Joy86] as a natural categorical setting for generating functions and bijections.

Definition 2. *A species F is a functor from the category of finite sets and bijections to the category of finite sets.*

This just means that, given a finite set I , there is a natural way to build a set $F(I)$ out of it, without using any specific properties of the elements of I .

This implies that there is a natural action of the bijections of I on $F(I)$.

Moreover F can be uniquely recovered from the collection $F(\{1, \dots, n\})$ and the action of symmetric groups.

For instance, one has the species L of lists: $L(I)$ is the set of total orders on I .

Most of the usual labelled combinatorial objects can be described by species.

For instance, there are species for labelled graphs, for labelled posets, for set partitions, for labelled hypergraphs, and so on.

As a “technology”, species have been used a lot by the UQAM team in combinatorics, see for instance the book [BLL98].

One can define operations on species:

$$\begin{aligned}
 (F')(I) &= F(I \sqcup \{\bullet\}) && \text{derivative,} \\
 (F \sqcup G)(I) &= F(I) \sqcup G(I) && \text{disjoint union,} \\
 (FG)(I) &= \bigsqcup_{I=J \sqcup K} F(J) \times G(K) && \text{product,} \\
 (F \cdot G)(I) &= F(I) \times G(I) && \text{Hadamard product,} \\
 (F \circ G)(I) &= \bigsqcup_{\simeq} F(I/\simeq) \times \prod_{J \in I/\simeq} G(J) && \text{composition,}
 \end{aligned}$$

where \simeq runs over the set of equivalence relations on I .

To each species F corresponds an exponential generating series:

$$F(x) = \sum_{n \geq 0} \#F(\{1, \dots, n\}) \frac{x^n}{n!}. \quad (19)$$

Each species F can be associated with a symmetric function

$$Z_F = \sum_{n \geq 0} Z_n(F), \quad (20)$$

where $Z_n(F)$ is the symmetric function associated with the action of the symmetric group \mathfrak{S}_n on the set $F(\{1, \dots, n\})$ (see the standard reference [Mac95] for more on symmetric functions).

The operations on species correspond to the same operations on generating functions or symmetric functions. For instance, composition of species corresponds to plethysm of symmetric functions.

4.2. Symmetric operads in sets. A symmetric operad in the category of sets is a species \mathcal{P} together with a morphism from $\mathcal{P} \circ \mathcal{P}$ to \mathcal{P} which takes the place of the composition map γ and should be associative.

The unit $\mathbf{1}$ is given by a natural system of distinguished elements in the images of singletons by the functor \mathcal{P} .

This is just an instance of the definition of a monoid in a monoidal category.

If one wants to use the analog of the \circ_i products instead of the γ maps, one can give, for all sets I, J and $i \in I$, maps

$$\circ_i : \mathcal{P}(I) \times \mathcal{P}(J) \longrightarrow \mathcal{P}(I \setminus \{i\} \sqcup J) \quad (21)$$

that have to satisfy some associativity axioms and naturality properties, the latter ones being generally obvious in all examples.

One can give an alternative axiomatics of symmetric operads by using instead of a species S the equivalent data of a collection of sets $S(n) = S(\{1, \dots, n\})$ with actions of the symmetric groups \mathfrak{S}_n .

This becomes heavy, because of **renumbering**. For instance, there is an operad on the species L where $L(I)$ is the set of total orders on I . This is the symmetric operad obtained from the non-symmetric operad Assoc by the introduction of free actions of symmetric groups. The composition \circ_i in L is given by insertion of a total order as a segment at some point of another one:

$$(b, a, c, f, e, d) \circ_c (u, r, p, s, t, q) = (b, a, u, r, p, s, t, q, f, e, d). \quad (22)$$

The same statement would become, after choosing the obvious numberings of $\{a, b, c, d, e, f\}$ and $\{p, q, r, s, t, u\}$:

$$(2, 1, 3, 6, 5, 4) \circ_3 (6, 3, 1, 4, 5, 2) = (2, 1, 8, 5, 3, 6, 7, 4, 11, 10, 9). \quad (23)$$

4.3. Example: the Commutative operad. The set $\text{Comm}(I)$ is just a singleton $\{I\}$ for all non-empty I .

As a species, this is usually called the species of non-empty sets denoted by E^+ , with generating series $E^+(x) = \exp(x) - 1$.

The unit is the unique element in $\text{Comm}(\{i\})$ for all singletons.

For composition, there is no choice.

Algebras over this operad are just commutative and associative algebras.

4.4. Rooted trees. Let us now introduce our second main player, a very well-known kind of tree.

Definition 3. *A rooted tree is a finite connected and simply connected graph with a distinguished vertex, called the root.*

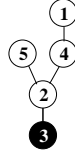
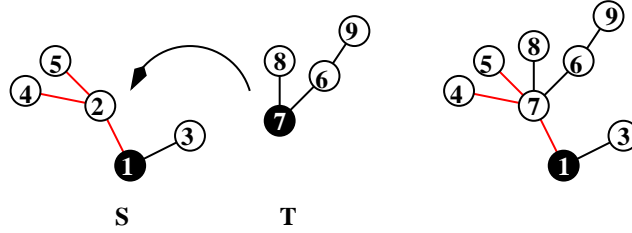
FIGURE 10. A rooted tree on the set $\{1, 2, 3, 4, 5\}$.FIGURE 11. Example of \circ_2 product in NAP from $\text{NAP}(\{1, 2, 3, 4, 5\}) \times \text{NAP}(\{6, 7, 8, 9\})$ to $\text{NAP}(\{1, 3, 4, 5, 6, 7, 8, 9\})$.

They are very classical combinatorial objects, going back at least to Cayley.

Proposition 4.1 (Classical result (Cayley)). *There are n^{n-1} distinct rooted trees with vertices $\{1, 2, \dots, n\}$.*

This statement has many proofs, some of them very elegant (see [AZ04, Chap. 24] and references therein).

4.5. The NAP operad. The NAP operad has been introduced by Livernet [Liv06]. The name NAP stands for “non-associative permutative.”

The set $\text{NAP}(I)$ is the set of rooted trees on I .

The unit is the unique rooted tree on the set $\{i\}$ for any singleton.

Composition \circ_i of a rooted tree T at the vertex i of a rooted tree S is described as follows.

Consider the forest obtained by removing the vertex i of S . Take the disjoint union with T . Add an edge between the root of T and all vertices of the forest that were connected to i in S .

The root of the result is taken to be the root of S if i is not the root of S and the root of T otherwise.

An example is given in Figure 11. One simply has to identify the root of T and the vertex i of S . The label i disappears.

4.6. Symmetric operads in vector spaces. One can play a similar game using vector spaces instead of finite sets.

A **vectorial species** is a functor from the category of finite sets and bijections to the category of vector spaces.

Just as before in the case of sets, this is equivalent to the notion of an \mathfrak{S} -module, which is the data of a collection of modules for all symmetric groups.

Then the same definition as in section 4.2, but considered for vectorial species instead of species, gives a notion of a symmetric operad in the category of vector spaces.

4.7. Example: the PreLie operad and pre-Lie algebras. Before explaining the pre-Lie operad, let us say a few words on the notion of a pre-Lie algebra which is attached to it.

The Pre-Lie operad has been introduced in [CL01]. But the notion of a pre-Lie algebra was known long before. It was used by Gerstenhaber in his study of deformation theory [Ger64]. There is a pre-Lie algebra structure on the Hochschild complex.

It was also used in relation with vector fields on the affine space, or more generally on spaces endowed with a flat and torsion-free connection, *i.e.*, an affine structure. The space of sections of the tangent bundle then has the structure of a pre-Lie algebra.

A pre-Lie algebra is a vector space with a product \curvearrowright satisfying

$$(x \curvearrowright y) \curvearrowright z - x \curvearrowright (y \curvearrowright z) = (x \curvearrowright z) \curvearrowright y - x \curvearrowright (z \curvearrowright y). \quad (24)$$

There are many specific examples of pre-Lie algebras, some of them more algebraic, others more combinatorial.

For instance, any operad gives a pre-Lie algebra. In the non-symmetric case, the pre-Lie product on the direct sum $\bigoplus_n \mathcal{P}(n)$ is given for $x \in \mathcal{P}(n)$ and $y \in \mathcal{P}(m)$ by

$$x \curvearrowright y = \sum_{i=1}^n x \circ_i y. \quad (25)$$

One can also define a pre-Lie algebra for any symmetric operad, in a similar way.

Pre-Lie algebras are devices which encode the combinatorics of the “sum of insertions at all possible places.”

For instance, one could consider trivalent graphs with three external legs. Then the sum of insertions at all possible vertices defines a pre-Lie product on the vector space spanned by these graphs.

Each pre-Lie algebra gives a Lie algebra, by the formula

$$[x, y] = x \curvearrowright y - y \curvearrowright x. \quad (26)$$

In this way, pre-Lie algebras are some kind of weak associative algebras. Once we have a Lie algebra, there is a group and a Hopf algebra also.

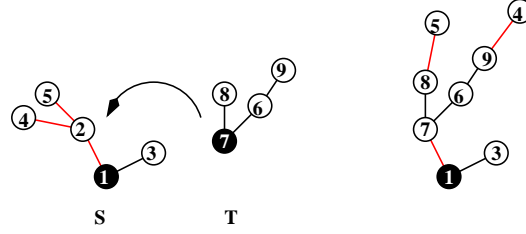
FIGURE 12. One term in a \circ_2 product in PreLie.

The commutative Hopf algebra of functions on the group has a nice property: when coordinates are chosen in a nice way, the coproduct is linear on one side.

On a more geometric side, this is related to the notion of a “group with a left-invariant affine structure.”

4.8. The PreLie operad. Let us now introduce the pre-Lie operad itself.

The set $\text{PreLie}(I)$ is the set of rooted trees on I .

The unit is the unique rooted tree on the set $\{i\}$ for any singleton.

In a rooted tree, one can orient the edges towards the root.

The composition \circ_i of a rooted tree T at the vertex i of a rooted tree S is described as a sum over the set of functions from incoming edges at vertex i in S to vertices of T . Pick such a function ϕ .

Consider the forest obtained by removing the vertex i of S . Take the disjoint union with T .

Add an edge between each vertex of the forest that was connected to i in S and the corresponding vertex of T given by ϕ .

If the vertex i had an outgoing edge in S , connect the other vertex of this edge to the root of T .

The root of the result is taken to be the root of S if i is not the root of S and the root of T otherwise.

Figure 12 displays one term in a \circ_2 product in PreLie from $\text{PreLie}(\{1, 2, 3, 4, 5\}) \times \text{PreLie}(\{6, 7, 8, 9\})$ to $\text{PreLie}(\{1, 3, 4, 5, 6, 7, 8, 9\})$.

The pre-Lie operad has more structure: it is an anticyclic operad [Cha05]. This means that there is natural action of the symmetric group \mathfrak{S}_{n+1} on the space $\text{PreLie}(\{1, \dots, n\})$ extending the action of \mathfrak{S}_n .

There is a similar “cyclic” structure on the operad Assoc, which is much easier to explain.

Recall that the operad Assoc (as a symmetric operad) is based on the species of lists: $\text{Assoc}(I)$ is the set of total orders on I .

One can uniquely extend a total order on I to a cyclic order on $I \sqcup \{\bullet\}$. Then there is an action of the bigger symmetric group of $I \sqcup \{\bullet\}$ on the set $\text{Assoc}(I)$.

Returning to the pre-Lie case, the action of the bigger symmetric group is not easy to describe. One way is to use the usual injective map from the pre-Lie operad into the Dendriform operad to restrict the cyclic action of the Dend operad.

One can for instance show that the iterated bracket (seen inside the PreLie operad)

$$[[\dots[[n, n-1], n-2], \dots, 2], 1] \quad (27)$$

is (up to sign) in the same orbit as the iterated pre-Lie product

$$((\dots((1 \curvearrowright 2) \curvearrowright 3) \dots n-1) \curvearrowright n). \quad (28)$$

So far, this action is only computable using the operad formalism. There is no known simpler alternative description.

5. FROM OPERADS TO GROUPS

There is a group associated with each operad. This group is defined on a set of generalised formal power series, which is equipped with a certain “composition” coming from the composition maps of the operad. The space of functions over this group is a commutative Hopf algebra, and one can translate everything in the language of Hopf algebras without difficulty.

We will give the construction and some examples of particularly nice elements in these groups, some of them being naturally generating series for some combinatorial objects. References for this construction are [vdL04, Cha02].

The definition is simpler for non-symmetric operads; let us start with this case. Let \mathcal{P} be a non-symmetric operad in the category of vector spaces. Let

$$\widehat{\mathcal{P}} = \prod_{n \geq 1} \mathcal{P}(n). \quad (29)$$

As a vector space, this is a completion of the free \mathcal{P} -algebra on one generator. On this space (seen as a set), there is an associative product $x \circ y$ which is linear in its left argument. If x is homogeneous of degree n and $y = \sum_{k \geq 1} y_k$, then

$$x \circ y = \sum_{k_1, \dots, k_n} \gamma(x; y_{k_1}, \dots, y_{k_n}). \quad (30)$$

The \circ product is associative and non-linear in its right argument. This gives a monoid structure on the set $\widehat{\mathcal{P}}$.

One can consider the group of invertible elements in this monoid.

The affine subspace of elements $x = \mathbf{1} + \sum_{k \geq 2} x_k$ is a subgroup.

For an operad \mathcal{P} , this will be called the \mathcal{P} -group.

This construction is functorial: a morphism of operads from \mathcal{P} to \mathcal{Q} gives a morphism of groups from the \mathcal{P} -group to the \mathcal{Q} -group.

There is a useful distributivity property between operations in the free \mathcal{P} -algebra and product on the right with an element G of the \mathcal{P} -group:

$$(m(A, B, \dots))G = m(AG, BG, \dots) \quad (31)$$

where A, B, \dots are elements in the free \mathcal{P} -algebra and $m(\dots)$ is the operation in the free \mathcal{P} -algebra induced by an element m of the operad \mathcal{P} .

For instance, in the case of the Associative operad, the associated group is just the group of series f in one variable t of the shape

$$f = t + \sum_{n \geq 2} f_n t^n \quad (32)$$

with the group law given by **composition** of such series. This group law is of course linear and multiplicative in its left argument: one has

$$(f \times g) \circ h = (f \circ h) \times (g \circ h). \quad (33)$$

In the case of a symmetric operad, the construction is mostly the same.

Let \mathcal{P} be a symmetric operad in the category of vector spaces. Let

$$\widehat{\mathcal{P}} = \prod_{n \geq 1} \mathcal{P}(\{1, \dots, n\})_{\mathfrak{S}_n}, \quad (34)$$

the product of the coinvariants for the action of the symmetric group. This is the completion of the free \mathcal{P} -algebra on one generator with respect to the filtration by n .

There is an associative product \circ on this space, defined by choosing representatives and using the γ maps of the operad just as before.

The affine subspace of series where the unit $\mathbf{1}$ has coefficient 1 is a group.

5.1. Series of planar binary trees: the OverUnder group. We give here examples of series in the group associated with the OU operad.

Let us say that a planar binary tree is a left comb (respectively a right comb) if it can be written as a power of the tree $\begin{array}{c} \diagup \\ \diagdown \end{array}$ for the $/$ product (respectively for the \backslash product). Let us say that a planar binary tree is a V-shaped tree if it is $\begin{array}{c} \diagup \\ \diagdown \end{array}$ or can be written as ℓ/r or $\ell \backslash r$ for some left comb ℓ and some right comb r .

Let us first introduce the sum of all planar binary trees:

$$\mathbf{A} = \begin{array}{c} \diagup \\ \diagdown \end{array} + \begin{array}{c} \diagdown \\ \diagup \end{array} + \begin{array}{c} \diagup \\ \diagdown \\ \diagup \\ \diagdown \end{array} + \begin{array}{c} \diagdown \\ \diagup \\ \diagdown \\ \diagup \end{array} + \begin{array}{c} \diagup \\ \diagdown \\ \diagup \\ \diagdown \\ \diagup \\ \diagdown \end{array} + \begin{array}{c} \diagdown \\ \diagup \\ \diagdown \\ \diagup \\ \diagdown \\ \diagup \end{array} + \begin{array}{c} \diagup \\ \diagdown \\ \diagup \\ \diagdown \\ \diagup \\ \diagdown \\ \diagup \\ \diagdown \end{array} + \dots,$$

and the alternating-sign sum of V-shaped trees

$$\mathbf{B} = \begin{array}{c} \diagup \\ \diagdown \end{array} - \begin{array}{c} \diagdown \\ \diagup \end{array} - \begin{array}{c} \diagup \\ \diagdown \\ \diagup \\ \diagdown \end{array} + \begin{array}{c} \diagdown \\ \diagup \\ \diagdown \\ \diagup \end{array} + \begin{array}{c} \diagup \\ \diagdown \\ \diagup \\ \diagdown \\ \diagup \\ \diagdown \end{array} + \begin{array}{c} \diagdown \\ \diagup \\ \diagdown \\ \diagup \\ \diagdown \\ \diagup \end{array} + \dots.$$

Theorem 5.1. *In the OverUnder group, one has $\mathbf{A} = \mathbf{B}^{-1}$.*

Proof. The series \mathbf{A} is easily seen to be the unique solution to

$$\mathbf{A} = \begin{array}{c} \diagup \diagdown \\ | \quad | \end{array} + \mathbf{A} / \begin{array}{c} \diagup \diagdown \\ | \quad | \end{array} + \begin{array}{c} \diagup \diagdown \\ | \quad | \end{array} \backslash \mathbf{A} + \mathbf{A} / \begin{array}{c} \diagup \diagdown \\ | \quad | \end{array} \backslash \mathbf{A}. \quad (35)$$

This amounts to saying that a planar binary tree has either zero, one (left or right) or two subtrees.

Multiplication on the right by \mathbf{A}^{-1} is distributive with respect to the over and under products. Hence one gets the following equation:

$$\mathbf{A}^{-1} = \begin{array}{c} \diagup \diagdown \\ | \quad | \end{array} - \begin{array}{c} \diagup \diagdown \\ | \quad | \end{array} / \mathbf{A}^{-1} - \mathbf{A}^{-1} \backslash \begin{array}{c} \diagup \diagdown \\ | \quad | \end{array} - \begin{array}{c} \diagup \diagdown \\ | \quad | \end{array} / \mathbf{A}^{-1} \backslash \begin{array}{c} \diagup \diagdown \\ | \quad | \end{array}. \quad (36)$$

One can check that \mathbf{B} satisfies this equation. The result follows by uniqueness. \square

This can be generalised, with the same proof, as follows. Let us introduce a series depending on one parameter a recording the Narayana statistic on all trees, which is the number of right oriented leaves (not counting the rightmost leaf):

$$\mathbf{A}_a = \begin{array}{c} \diagup \diagdown \\ | \quad | \end{array} + a \begin{array}{c} \diagup \diagdown \\ | \quad | \end{array} + \begin{array}{c} \diagup \diagdown \\ | \quad | \end{array} + a^2 \begin{array}{c} \diagup \diagdown \\ | \quad | \end{array} + a \begin{array}{c} \diagup \diagdown \\ | \quad | \end{array} + a \begin{array}{c} \diagup \diagdown \\ | \quad | \end{array} + a \begin{array}{c} \diagup \diagdown \\ | \quad | \end{array} + \begin{array}{c} \diagup \diagdown \\ | \quad | \end{array} + \dots .$$

One can consider the same statistic restricted to V-shaped trees and with alternating signs:

$$\mathbf{B}_a = \begin{array}{c} \diagup \diagdown \\ | \quad | \end{array} - a \begin{array}{c} \diagup \diagdown \\ | \quad | \end{array} - \begin{array}{c} \diagup \diagdown \\ | \quad | \end{array} + a^2 \begin{array}{c} \diagup \diagdown \\ | \quad | \end{array} + a \begin{array}{c} \diagup \diagdown \\ | \quad | \end{array} + \begin{array}{c} \diagup \diagdown \\ | \quad | \end{array} + \dots .$$

Theorem 5.2. *In the OverUnder group, one has $\mathbf{A}_a = \mathbf{B}_a^{-1}$.*

Let us now introduce the sum of left combs:

$$\mathbf{C} = \begin{array}{c} \diagup \diagdown \\ | \quad | \end{array} + \begin{array}{c} \diagup \diagdown \\ | \quad | \end{array} + \begin{array}{c} \diagup \diagdown \\ | \quad | \end{array} + \dots ,$$

and the sum of right combs:

$$\mathbf{D} = \begin{array}{c} \diagup \diagdown \\ | \quad | \end{array} + \begin{array}{c} \diagup \diagdown \\ | \quad | \end{array} + \begin{array}{c} \diagup \diagdown \\ | \quad | \end{array} + \dots .$$

It follows from Theorem 5.2 that the inverse of \mathbf{C} in the OverUnder group is the alternating version of \mathbf{C} .

One has

$$\mathbf{C} + \mathbf{C} \backslash \mathbf{D} = \mathbf{D} + \mathbf{C} / \mathbf{D}. \quad (37)$$

This just means that a V-shaped tree can be decomposed using right combs and left combs in two different ways.

The **Tamari lattice** [HT72] is a well-known partial order on the set of planar binary trees with n vertices. The minimal element is the left comb tree, the maximal element is the right comb tree. The covering relations are given by local moves of the shape $\begin{array}{c} \diagup \diagdown \\ | \quad | \end{array} \leq \begin{array}{c} \diagup \diagdown \\ | \quad | \end{array}$.

Theorem 5.4. *In the Dendriform group, these series satisfy*

$$\Theta = \text{Y} + \text{Y} * \Phi \quad \text{and} \quad \Phi = \Theta + \Phi/\Theta, \tag{39}$$

where $*$ is the associative product in the free dendriform algebra (given by the element $\text{Y} + \text{Y}$ in the Dendriform operad).

These equations are proved in a combinatorial way, see [Cha06].

There are nice one-parameter (“quantum”) generalisations of these series, satisfying

$$\Theta = \text{Y} + \text{Y} * \Phi \quad \text{and} \quad \Phi = \Theta + q \Phi/\Theta. \tag{40}$$

As there is a map from the Associative operad to the Dendriform operad, one gets a map from the group of formal power series in one variable to the Dendriform group.

This map sends a series $\sum_{n \geq 1} f_n t^n$ to the sum of planar binary trees where all trees of degree n have the same coefficient f_n .

$$\begin{aligned} f &= \sum_{n \geq 1} f_n t^n \\ \mapsto F &= f_1 \text{Y} + f_2 (\text{Y} + \text{Y}) + f_3 (\text{Y} + \text{Y} + \text{Y} + \text{Y} + \text{Y}) + \dots \end{aligned} \tag{41}$$

Hence, these series form a sub-group of the Dendriform group.

Recall that we introduced at some point an operad M containing Dend, with $M(n) = \mathbb{Q}(u_1, \dots, u_n)$.

There is also an associated group, containing the Dend group. Its elements are formal sums of rational functions in different numbers of arguments. This is what is called a mould by Ecalle, though he is using a different group structure and works with more complicated functions, with $2n$ variables, which do not fit in the present framework.

5.3. Series of rooted trees: the NAP group. Let us introduce the sum of all corollas:

$$\mathbf{C} = \bullet + \bullet + \bullet + \bullet + \bullet + \dots, \tag{42}$$

and the alternating sum of linear trees:

$$\mathbf{L} = \bullet - \bullet + \bullet - \bullet + \bullet - \dots \tag{43}$$

Theorem 5.5. *In the NAP group, $\mathbf{C} = \mathbf{L}^{-1}$.*

The proof uses the functional equation

$$C = \bullet + C \triangleleft \bullet, \quad (44)$$

where \triangleleft is the NAP product on rooted trees; the product $S \triangleleft T$ is obtained by grafting the root of T on the root of S .

Consider now the series where each rooted tree has weight the inverse of the order of its automorphism group:

$$A = \bullet + \begin{array}{c} \circ \\ | \\ \bullet \end{array} + \frac{1}{2} \begin{array}{c} \circ \quad \circ \\ | \quad | \\ \bullet \end{array} + \begin{array}{c} \circ \\ | \\ \bullet \end{array} + \frac{1}{6} \begin{array}{c} \circ \quad \circ \quad \circ \\ | \quad | \quad | \\ \bullet \end{array} + \frac{1}{2} \begin{array}{c} \circ \quad \circ \\ | \quad | \\ \bullet \end{array} + \begin{array}{c} \circ \quad \circ \\ | \quad | \\ \bullet \end{array} + \begin{array}{c} \circ \\ | \\ \bullet \end{array} + \dots . \quad (45)$$

The inverse of A in the NAP group is the analogous sum restricted to corollas but with alternating signs:

$$C = \bullet - \begin{array}{c} \circ \\ | \\ \bullet \end{array} + \frac{1}{2} \begin{array}{c} \circ \quad \circ \\ | \quad | \\ \bullet \end{array} - \frac{1}{6} \begin{array}{c} \circ \quad \circ \quad \circ \\ | \quad | \quad | \\ \bullet \end{array} + \frac{1}{24} \begin{array}{c} \circ \quad \circ \quad \circ \quad \circ \\ | \quad | \quad | \quad | \\ \bullet \end{array} + \dots . \quad (46)$$

Here the proof is more sophisticated and uses a relationship with some incidence algebras, see [CL07].

There are two morphisms from the NAP group to the **multiplicative** group of formal power series: either projects on corollas or on linear trees. The reader may want to check that this works in the examples given above.

There is a morphism from the NAP group to the group of formal power series for **composition** given by the sum of the coefficients of all trees of same degree. This comes from a morphism from NAP to the Associative operad.

This is clear in the first example above. In the second example, this is less obvious. The image of A is related to the so-called Lambert W function which is the functional inverse of $x \exp(x)$.

5.4. Series of rooted trees: the PreLie group. The PreLie group has the same underlying set as the NAP group, but they are distinct.

Consider again the series where each rooted tree has weight the inverse of the order of its automorphism group.

$$A = \bullet + \begin{array}{c} \circ \\ | \\ \bullet \end{array} + \frac{1}{2} \begin{array}{c} \circ \quad \circ \\ | \quad | \\ \bullet \end{array} + \begin{array}{c} \circ \\ | \\ \bullet \end{array} + \frac{1}{6} \begin{array}{c} \circ \quad \circ \quad \circ \\ | \quad | \quad | \\ \bullet \end{array} + \frac{1}{2} \begin{array}{c} \circ \quad \circ \\ | \quad | \\ \bullet \end{array} + \begin{array}{c} \circ \quad \circ \\ | \quad | \\ \bullet \end{array} + \begin{array}{c} \circ \\ | \\ \bullet \end{array} + \dots . \quad (47)$$

Then the inverse of A in the PreLie group is the alternating-sign version of A .

The proof goes as follows: first one has to describe the image of A in the Dend group, then compute the inverse of this image. Details will appear elsewhere.

Consider now the following series

$$\Delta(s, t) = \bullet + (s + t) \begin{array}{c} \circ \\ | \\ \bullet \end{array} + (s^2 + st) \begin{array}{c} \circ \quad \circ \\ | \quad | \\ \bullet \end{array} + (s^2 + 2st + t^2) \begin{array}{c} \circ \\ | \\ \bullet \end{array} + \dots , \quad (48)$$

which is defined by the equation

$$\Delta = \bullet + s \Delta \frown \bullet + t \bullet \frown \Delta.$$

From this equation, it follows that the inverse of $\Delta(s, t)$ in the PreLie group is the alternating-sign version of $\Delta(t, s)$.

One can show that Δ is related to the statistic “number of cycles” in permutations.

There is a morphism from the PreLie group to the **multiplicative** group of formal power series, given by projection on corollas.

There is a morphism from the PreLie group to the group of formal power series for **composition**, given by projection on linear trees.

The sum of the coefficients of all trees of same degree defines a morphism from the PreLie group to a group of formal power series related to the Witt Lie algebra.

There is a morphism from the PreLie group to the Dend group, coming from the morphism from PreLie to Dend.

6. CONCLUSION

This brief text can not claim to any kind of completeness. We have forgotten many aspects of operads, focusing on the more combinatorial ones.

- There are many more nice operads and morphisms between them.
- There are many other interesting series in the associated groups.
- These series over trees can be seen as refined generating series. They can be useful in enumerative problems.
- There are plenty of interesting Hopf algebras related to these groups.
- Some of these operads and associated groups are implemented in the computer algebra system MuPAD.

REFERENCES

- [AB03] J.-C. Aval and N. Bergeron. Catalan paths and quasi-symmetric functions. *Proc. Amer. Math. Soc.*, 131(4):1053–1062 (electronic), 2003.
- [ABB04] J.-C. Aval, F. Bergeron, and N. Bergeron. Ideals of quasi-symmetric functions and super-covariant polynomials for S_n . *Adv. Math.*, 181(2):353–367, 2004.
- [AZ04] Martin Aigner and Günter M. Ziegler. *Proofs from The Book*. Springer-Verlag, Berlin, third edition, 2004. Including illustrations by Karl H. Hofmann.
- [Bes03] D. Bessis. The dual braid monoid. *Ann. Sci. École Norm. Sup. (4)*, 36(5):647–683, 2003.
- [BLL98] F. Bergeron, G. Labelle, and P. Leroux. *Combinatorial species and tree-like structures*, volume 67 of *Encyclopedia of Mathematics and its Applications*. Cambridge University Press, Cambridge, 1998. Translated from the 1994 French original by Margaret Readdy, With a foreword by Gian-Carlo Rota.

- [BMR⁺06] A. B. Buan, R. Marsh, M. Reineke, I. Reiten, and G. Todorov. Tilting theory and cluster combinatorics. *Adv. Math.*, 204(2):572–618, 2006.
- [But72] J. C. Butcher. An algebraic theory of integration methods. *Math. Comp.*, 26:79–106, 1972.
- [BV73] J. M. Boardman and R. M. Vogt. *Homotopy invariant algebraic structures on topological spaces*. Springer-Verlag, Berlin, 1973. Lecture Notes in Mathematics, Vol. 347.
- [CGH⁺96] R. M. Corless, G. H. Gonnet, D. E. G. Hare, D. J. Jeffrey, and D. E. Knuth. On the Lambert W function. *Adv. Comput. Math.*, 5(4):329–359, 1996.
- [Cha02] F. Chapoton. Rooted trees and an exponential-like series, 2002. unpublished, arXiv:math.QA/0209104.
- [Cha05] F. Chapoton. On some anticyclic operads. *Algebr. Geom. Topol.*, 5:53–69 (electronic), 2005.
- [Cha06] F. Chapoton. Sur le nombre d’intervalles dans les treillis de Tamari. *Séminaire Lotharingien de Combinatoire*, 55:B55f, 2006. <http://www.citebase.org/abstract?id=oai:arXiv.org:math/0602368>.
- [Cha07] F. Chapoton. The anticyclic operad of moulds. *IMRN*, 2007. doi:10.1093/imrn/rnm078.
- [CK98] A. Connes and D. Kreimer. Hopf algebras, renormalization and noncommutative geometry. *Comm. Math. Phys.*, 199(1):203–242, 1998.
- [CL01] F. Chapoton and M. Livernet. Pre-Lie algebras and the rooted trees operad. *Internat. Math. Res. Notices*, (8):395–408, 2001.
- [CL07] F. Chapoton and M. Livernet. Relating two Hopf algebras built from an operad. *IMRN*, rnm131:27, 2007. doi:10.1093/imrn/rnm131.
- [Eca03] J. Ecalle. ARI/GARI, la dimorphie et l’arithmétique des multizêtas: un premier bilan. *J. Théor. Nombres Bordeaux*, 15(2):411–478, 2003.
- [Fra08] A. Frabetti. Groups of tree-expanded series. *Journal of Algebra*, 319(1):377–413, 2008.
- [FZ03] S. Fomin and A. Zelevinsky. Y -systems and generalized associahedra. *Ann. of Math. (2)*, 158(3):977–1018, 2003.
- [Ger64] M. Gerstenhaber. On the deformation of rings and algebras. *Ann. of Math. (2)*, 79:59–103, 1964.
- [GK94] Victor Ginzburg and Mikhail Kapranov. Koszul duality for operads. *Duke Math. J.*, 76(1):203–272, 1994.
- [GK95] E. Getzler and M. M. Kapranov. Cyclic operads and cyclic homology. In *Geometry, topology, & physics*, Conf. Proc. Lecture Notes Geom. Topology, IV, pages 167–201. Int. Press, Cambridge, MA, 1995.
- [Hil06] L. Hille. On the volume of a tilting module. *Abh. Math. Sem. Univ. Hamburg*, 76:261–277, 2006.
- [HT72] S. Huang and D. Tamari. Problems of associativity: A simple proof for the lattice property of systems ordered by a semi-associative law. *J. Combinatorial Theory Ser. A*, 13:7–13, 1972.
- [Joy86] A. Joyal. Foncteurs analytiques et espèces de structures. In *Combinatoire énumérative (Montreal, Que., 1985/Quebec, Que., 1985)*, volume 1234 of *Lecture Notes in Math.*, pages 126–159. Springer, Berlin, 1986.
- [Lab81] Gilbert Labelle. Une nouvelle démonstration combinatoire des formules d’inversion de Lagrange. *Adv. in Math.*, 42(3):217–247, 1981.

- [Liv06] M. Livernet. A rigidity theorem for pre-Lie algebras. *J. Pure Appl. Algebra*, 207(1):1–18, 2006.
- [Lod96] J.-L. Loday. La renaissance des opérades. *Astérisque*, (237):Exp. No. 792, 3, 47–74, 1996. Séminaire Bourbaki, Vol. 1994/95.
- [Lod01] J.-L. Loday. Dialgebras. In *Dialgebras and related operads*, volume 1763 of *Lecture Notes in Math.*, pages 7–66. Springer, Berlin, 2001.
- [LR02] J.-L. Loday and M. O. Ronco. Order structure on the algebra of permutations and of planar binary trees. *J. Algebraic Combin.*, 15(3):253–270, 2002.
- [LSV97] J.-L. Loday, J. D. Stasheff, and A. A. Voronov, editors. *Operads: Proceedings of Renaissance Conferences*, volume 202 of *Contemporary Mathematics*. American Mathematical Society, Providence, RI, 1997. Papers from the Special Session on Moduli Spaces, Operads and Representation Theory held at the AMS Meeting in Hartford, CT, March 4–5, 1995, and from the Conference on Operads and Homotopy Algebra held in Luminy, May 29–June 2, 1995.
- [Mac95] I. G. Macdonald. *Symmetric functions and Hall polynomials*. Oxford Mathematical Monographs. The Clarendon Press Oxford University Press, New York, second edition, 1995. With contributions by A. Zelevinsky, Oxford Science Publications.
- [May72] J. P. May. *The geometry of iterated loop spaces*. Springer-Verlag, Berlin, 1972. Lectures Notes in Mathematics, Vol. 271.
- [MSS02] M. Markl, S. Shnider, and J. Stasheff. *Operads in algebra, topology and physics*, volume 96 of *Mathematical Surveys and Monographs*. American Mathematical Society, Providence, RI, 2002.
- [Noy98] M. Noy. Enumeration of noncrossing trees on a circle. In *Proceedings of the 7th Conference on Formal Power Series and Algebraic Combinatorics (Noisy-le-Grand, 1995)*, *Discrete Math.*, volume 180, pages 301–313, 1998.
- [Pit99] Jim Pitman. Coalescent random forests. *J. Combin. Theory Ser. A*, 85(2):165–193, 1999.
- [Smi01] V. A. Smirnov. *Simplicial and operad methods in algebraic topology*, volume 198 of *Translations of Mathematical Monographs*. American Mathematical Society, Providence, RI, 2001. Translated from the Russian manuscript by G. L. Rybnikov.
- [Sta97] R. P. Stanley. *Enumerative combinatorics. Vol. 1*, volume 49 of *Cambridge Studies in Advanced Mathematics*. Cambridge University Press, Cambridge, 1997. With a foreword by Gian-Carlo Rota, Corrected reprint of the 1986 original.
- [vdL04] P. van der Laan. *Operads. Hopf algebras and coloured Koszul duality*. PhD thesis, Universiteit Utrecht, 2004.